

Form 5 Chapter 6
Trigonometric Functions
Fully-Worked Solutions

UPSKILL 6.1

1 (a)

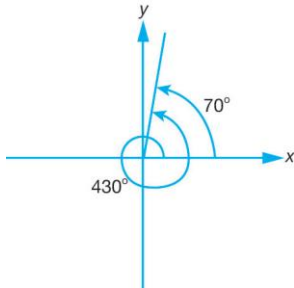

First quadrant

(b)

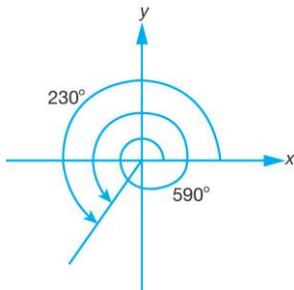

Third quadrant

(c)

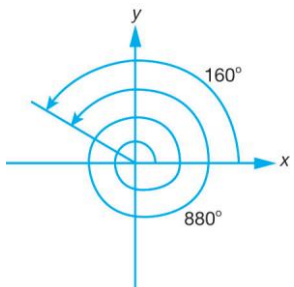

Second quadrant

(d)

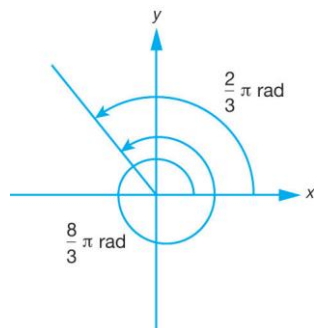

Second quadrant

(e)

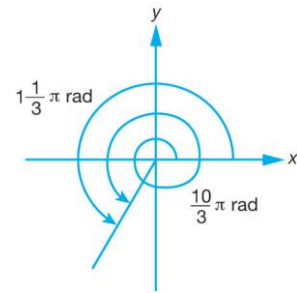

Third quadrant

(f)

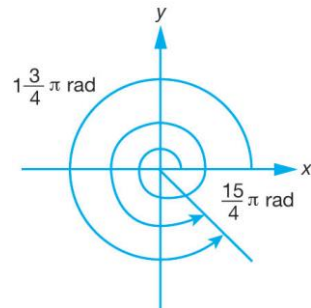

Fourth quadrant

2 (a)

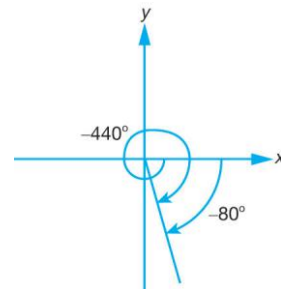

Fourth quadrant

(b)

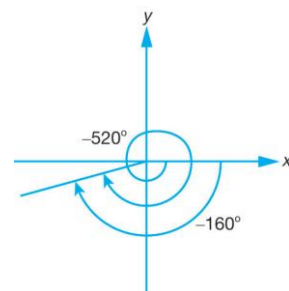

Third quadrant

(c)

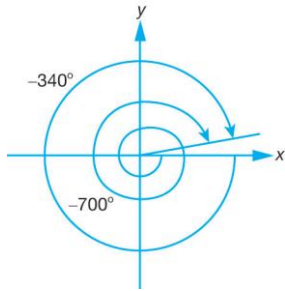

First quadrant

(d)

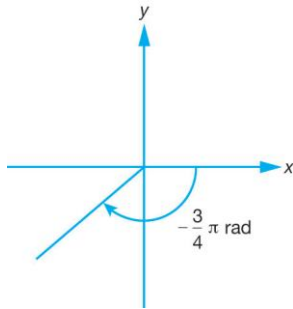

Third quadrant

(e)

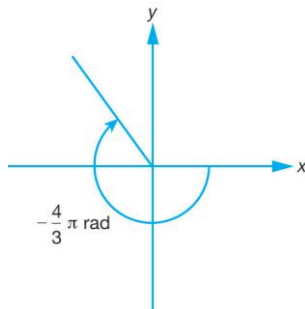

Second quadrant

(f)

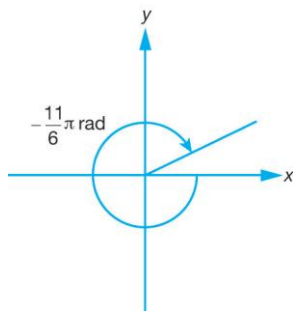

First quadrant

UPSKILL 6.2

$$1 \text{ (a) } \tan 15^\circ = \frac{\sin 15^\circ}{\cos 15^\circ} = \frac{0.2588}{0.9659} = 0.2679$$

$$(b) \cot 15^\circ = \frac{\cos 15^\circ}{\sin 15^\circ} = \frac{0.9659}{0.2588} = 3.7322$$

$$(c) \sec 15^\circ = \frac{1}{\cos 15^\circ} = \frac{1}{0.9659} = 1.0353$$

$$(d) \operatorname{cosec} 15^\circ = \frac{1}{\sin 15^\circ} = \frac{1}{0.2588} = 3.8640$$

$$2 \text{ (a) } \tan \frac{2}{3}\pi = \frac{\sin \frac{2}{3}\pi}{\cos \frac{2}{3}\pi} = \frac{0.8660}{-0.5} = -1.732$$

$$(b) \cot \frac{2}{3}\pi = \frac{\cos \frac{2}{3}\pi}{\sin \frac{2}{3}\pi} = \frac{-0.5}{0.8660} = -0.5774$$

$$(c) \sec \frac{2}{3}\pi = \frac{1}{\cos \frac{2}{3}\pi} = \frac{1}{-0.5} = -2$$

$$(d) \operatorname{cosec} \frac{2}{3}\pi = \frac{1}{\sin \frac{2}{3}\pi} = \frac{1}{0.8660} = 1.1547$$

$$3 \text{ (a) } \tan 30^\circ = \frac{\sin 30^\circ}{\cos 30^\circ} = \frac{\frac{1}{2}}{\frac{\sqrt{3}}{2}} = \frac{1}{\sqrt{3}}$$

$$(b) \cot 30^\circ = \frac{\cos 30^\circ}{\sin 30^\circ} = \frac{\frac{\sqrt{3}}{2}}{\frac{1}{2}} = \sqrt{3}$$

$$(c) \sec 30^\circ = \frac{1}{\cos 30^\circ} = \frac{1}{\frac{\sqrt{3}}{2}} = \frac{2}{\sqrt{3}}$$

$$(d) \operatorname{cosec} 30^\circ = \frac{1}{\sin 30^\circ} = \frac{1}{\frac{1}{2}} = 2$$

$$4 \text{ (a) } \cos 150^\circ = -\cos (180^\circ - 150^\circ) \\ = -\cos 30^\circ \\ = -\frac{\sqrt{3}}{2}$$

$$\begin{aligned}
 \text{(b) } \sin 225^\circ &= -\sin(225^\circ - 180^\circ) \\
 &= -\sin 45^\circ \\
 &= -\frac{1}{\sqrt{2}}
 \end{aligned}$$

$$\begin{aligned}
 \text{(c) } \tan 240^\circ &= \tan(240^\circ - 180^\circ) \\
 &= \tan 60^\circ \\
 &= \sqrt{3}
 \end{aligned}$$

$$\begin{aligned}
 \text{(d) } \cos\left(\frac{7}{4}\pi\right) &= \cos\left(\frac{7}{4}\times 180^\circ\right) \\
 &= \cos 315^\circ \\
 &= \cos(360^\circ - 315^\circ) \\
 &= \cos 45^\circ \\
 &= \frac{1}{\sqrt{2}}
 \end{aligned}$$

$$\begin{aligned}
 \text{(e) } \operatorname{cosec} 135^\circ &= \frac{1}{\sin 135^\circ} \\
 &= \frac{1}{\sin(180^\circ - 135^\circ)} \\
 &= \frac{1}{\sin 45^\circ} \\
 &= \frac{1}{\frac{1}{\sqrt{2}}} \\
 &= \sqrt{2}
 \end{aligned}$$

$$\begin{aligned}
 \text{(f) } \sec 570^\circ &= \sec(570^\circ - 360^\circ) \\
 &= \sec(210^\circ) \\
 &= \frac{1}{\cos 210^\circ} \\
 &= \frac{1}{-\cos(210^\circ - 180^\circ)} \\
 &= \frac{1}{-\cos 30^\circ} \\
 &= -\frac{1}{\frac{\sqrt{3}}{2}} \\
 &= -\frac{2}{\sqrt{3}}
 \end{aligned}$$

$$\begin{aligned}
 \text{(g) } \cot 870^\circ &= \cot(870^\circ - 720^\circ) \\
 &= \cot 150^\circ \\
 &= \frac{1}{-\tan(180^\circ - 150^\circ)} \\
 &= \frac{1}{-\tan(30^\circ)} \\
 &= -\frac{1}{\frac{1}{\sqrt{3}}} \\
 &= -\sqrt{3}
 \end{aligned}$$

$$\begin{aligned}
 \text{(h) } \operatorname{cosec}\left(-\frac{11}{3}\pi\right) &= \operatorname{cosec}\left(-\frac{11}{3}\times 180^\circ\right) \\
 &= \operatorname{cosec}(-660^\circ) \\
 &= \operatorname{cosec}(-660^\circ + 720^\circ) \\
 &= \operatorname{cosec}(60^\circ) \\
 &= \frac{1}{\sin 60^\circ} \\
 &= \frac{1}{\frac{\sqrt{3}}{2}} \\
 &= \frac{2}{\sqrt{3}}
 \end{aligned}$$

5

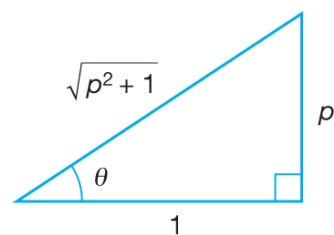

$$\begin{aligned}
 \text{(a) } \operatorname{cosec} \theta &= \frac{1}{\sin \theta} \\
 &= \frac{1}{\frac{p}{\sqrt{p^2 + 1}}} \\
 &= \frac{\sqrt{p^2 + 1}}{p}
 \end{aligned}$$

$$\begin{aligned}
 \text{(b) } \cos(-\theta) &= \cos \theta \\
 &= \frac{1}{\sqrt{p^2 + 1}}
 \end{aligned}$$

6

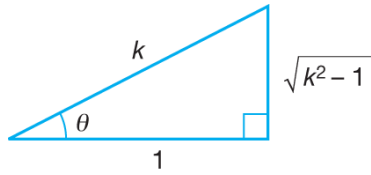

$$\begin{aligned} \text{(a) } \sin(-\theta) &= -\sin \theta \\ &= -\frac{\sqrt{k^2 - 1}}{k} \end{aligned}$$

$$\begin{aligned} \text{(b) } \sec(-\theta) &= \frac{1}{\cos(-\theta)} \\ &= \frac{1}{\cos \theta} \\ &= \frac{1}{\frac{1}{k}} \\ &= k \end{aligned}$$

$$\begin{aligned} \text{(c) } \cot(-\theta) &= \frac{1}{\tan(-\theta)} \\ &= \frac{1}{-\tan \theta} \\ &= -\frac{1}{\sqrt{k^2 - 1}} \end{aligned}$$

$$\text{7 (a) } \sin 2\theta = 0.5278$$

$$\begin{aligned} \text{Basic } \angle &= 31.86^\circ \\ 2\theta &= 31.86^\circ, 148.14^\circ, 391.86^\circ, 508.14^\circ \\ \theta &= 15.93^\circ, 74.07^\circ, 195.93^\circ, 254.07^\circ \end{aligned}$$

$$\text{(b) } \cos 2\theta = -0.4630$$

$$\begin{aligned} \text{Basic } \angle &= 62.42^\circ \\ 2\theta &= 117.58^\circ, 242.42^\circ, 477.58^\circ, 602.42^\circ \\ \theta &= 58.79^\circ, 121.21^\circ, 238.79^\circ, 301.21^\circ \end{aligned}$$

$$\text{(c) } \tan 2\theta = -0.4287$$

$$\begin{aligned} \text{Basic } \angle &= 23.20^\circ \\ 2\theta &= 156.80^\circ, 336.80^\circ, 516.80^\circ, 696.80^\circ \\ \theta &= 78.40^\circ, 168.40^\circ, 258.40^\circ, 348.40^\circ \end{aligned}$$

$$\text{(d) } \sin 3\theta = -0.4479$$

$$\begin{aligned} \text{Basic } \angle &= 26.61^\circ \\ 3\theta &= 206.61^\circ, 333.39^\circ, 566.61^\circ, \\ &693.39^\circ, 926.61^\circ, 1\,053.39^\circ \\ \theta &= 68.87^\circ, 111.13^\circ, 188.87^\circ, \\ &231.13^\circ, 308.87^\circ, 351.13^\circ \end{aligned}$$

$$\text{(e) } \cos 3\theta = 0.5358$$

$$\begin{aligned} \text{Basic } \angle &= 57.60^\circ \\ 3\theta &= 57.60^\circ, 302.40^\circ, 417.60^\circ, \\ &662.40^\circ, 777.60^\circ, 1\,022.40^\circ \\ \theta &= 19.20^\circ, 100.80^\circ, 139.20^\circ, \\ &220.80^\circ, 259.20^\circ, 340.80^\circ \end{aligned}$$

$$\text{(f) } \tan 3\theta = 1.5849$$

$$\begin{aligned} \text{Basic } \angle &= 57.75^\circ \\ 3\theta &= 57.75^\circ, 237.75^\circ, 417.75^\circ, \\ &597.75^\circ, 777.75^\circ, 957.75^\circ \\ \theta &= 19.25^\circ, 79.25^\circ, 139.25^\circ, \\ &199.25^\circ, 259.25^\circ, 319.25^\circ \end{aligned}$$

$$\text{8 (a) } \sin x = \cos 65^\circ$$

$$\sin x = \sin(90^\circ - 65^\circ)$$

$$\sin x = \sin 25^\circ$$

$$\text{Basic } \angle = 25^\circ$$

$$x = 25^\circ, 155^\circ$$

$$\text{(b) } \cos x = \sin 47^\circ$$

$$\cos x = \cos(90^\circ - 47^\circ)$$

$$\cos x = \cos 43^\circ$$

$$\text{Basic } \angle = 43^\circ$$

$$x = 43^\circ, 317^\circ$$

$$\text{(c) } \tan x = \cot 83^\circ$$

$$\tan x = \tan(90^\circ - 83^\circ)$$

$$\tan x = \tan 7^\circ$$

$$\text{Basic } \angle = 7^\circ$$

$$x = 7^\circ, 187^\circ$$

UPSKILL 6.3a

- (d) $\sec x = \operatorname{cosec} 56^\circ$
 $\sec x = \sec(90^\circ - 56^\circ)$
 $\sec x = \sec 34^\circ$
 Basic $\angle = 34^\circ$
 $x = 34^\circ, 326^\circ$
- (e) $\sec x = -\operatorname{cosec} 48^\circ$
 $\sec x = -\sec(90^\circ - 48^\circ)$
 $\sec x = -\sec 42^\circ$
 Basic $\angle = 42^\circ$
 $x = 138^\circ, 222^\circ$
- (f) $\sin 2x = -\cos 66^\circ$
 $\sin 2x = -\sin(90^\circ - 66^\circ)$
 $\sin 2x = -\sin 24^\circ$
 Basic $\angle = 24^\circ$
 $2x = 204^\circ, 336^\circ, 564^\circ, 696^\circ$
 $x = 102^\circ, 168^\circ, 282^\circ, 348^\circ$
- (g) $\cos 2x = -\sin 72^\circ$
 $\cos 2x = -\cos(90^\circ - 72^\circ)$
 $\cos 2x = -\cos 18^\circ$
 Basic $\angle = 18^\circ$
 $2x = 162^\circ, 198^\circ, 522^\circ, 558^\circ$
 $x = 81^\circ, 99^\circ, 261^\circ, 279^\circ$
- (h) $\tan 3x = \cot 57^\circ$
 $\tan 3x = \tan(90^\circ - 57^\circ)$
 $\tan 3x = \tan 33^\circ$
 Basic $\angle = 33^\circ$
 $3x = 33^\circ, 213^\circ, 393^\circ, 573^\circ, 753^\circ, 933^\circ$
 $x = 11^\circ, 71, 131^\circ, 191^\circ, 251^\circ, 311^\circ$

1 (a)

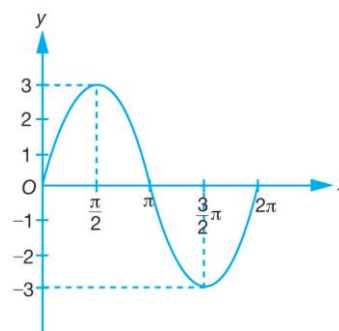

(b)

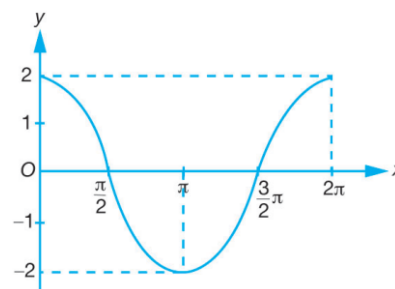

(c)

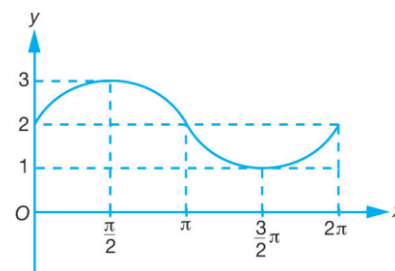

(d)

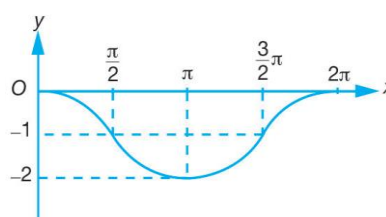

2 (a)

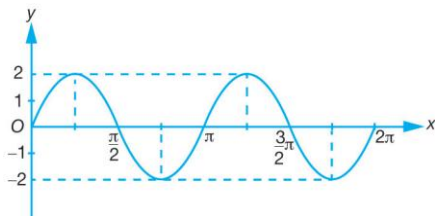

(b)

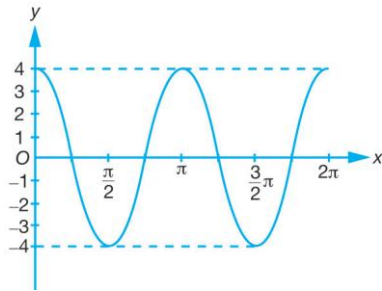

(c)

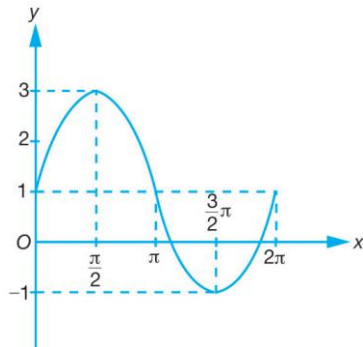

(d)

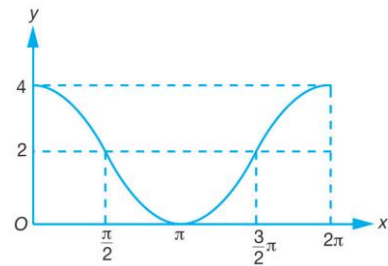

(e)

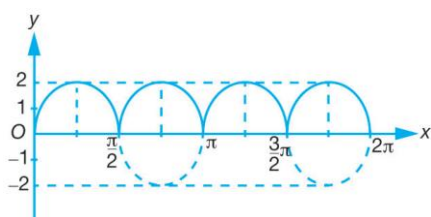

(f)

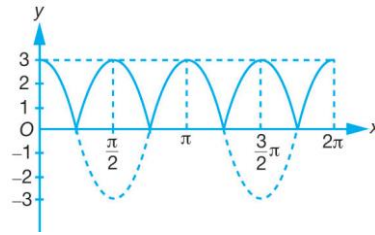

(g)

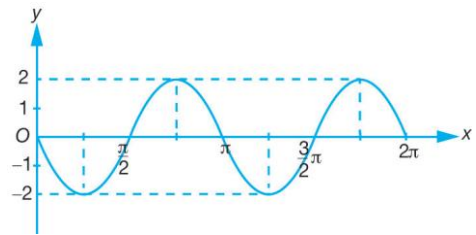

(h)

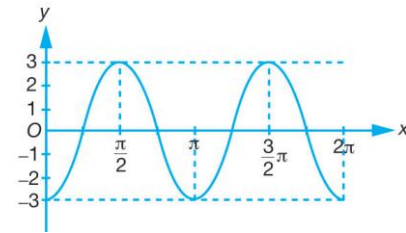

(i)

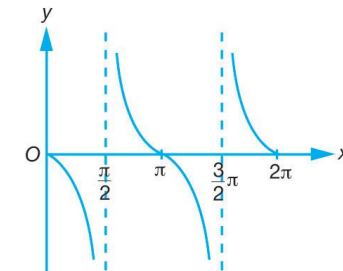

UPSKILL 6.3b

1

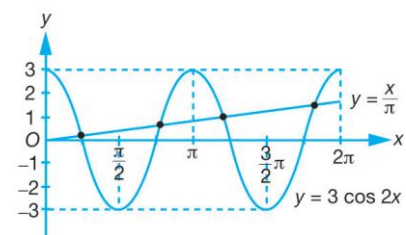

$$3\pi \cos 2x = x$$

$$3 \cos 2x = \frac{x}{\pi}$$

Number of solutions
 = Number of points of intersection
 = 4

2

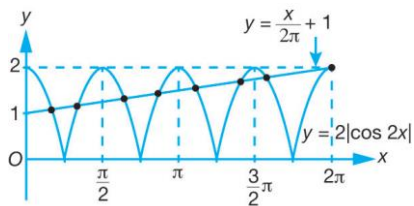

$$2\pi(2|\cos 2x| - 1) = x$$

$$2|\cos 2x| - 1 = \frac{x}{2\pi}$$

$$2|\cos 2x| = \frac{x}{2\pi} + 1$$

Number of solutions
 = Number of points of intersection
 = 8

3

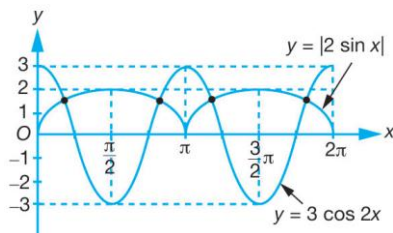

Number of solutions
 = Number of points of intersection
 = 4

4 (a)

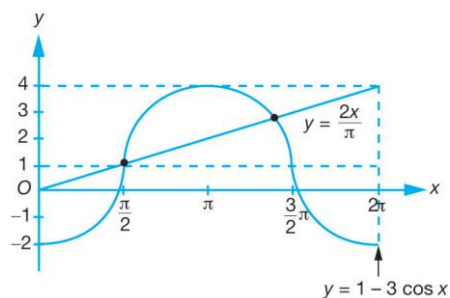

(b) $\pi - 3\pi \cos x = 2x$
 $\pi(1 - 3 \cos x) = 2x$

$$1 - 3 \cos x = \frac{2x}{\pi}$$

Sketch the straight line $y = \frac{2x}{\pi}$

(c) Number of solutions
 = Number of points of intersection
 = 2

5 (a)

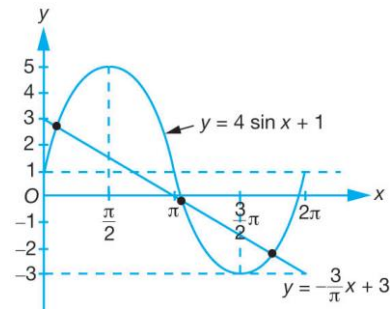

(b) $4\pi \sin x = 2\pi - 3x$

$$4 \sin x = \frac{2\pi - 3x}{\pi}$$

$$4 \sin x + 1 = \frac{2\pi - 3x}{\pi} + 1$$

$$4 \sin x + 1 = 2 - \frac{3}{\pi}x + 1$$

$$4 \sin x + 1 = 3 - \frac{3}{\pi}x$$

Sketch the straight line $y = -\frac{3}{\pi}x + 3$

(c) Number of solutions
 = Number of points of intersection
 = 3

6 (a)

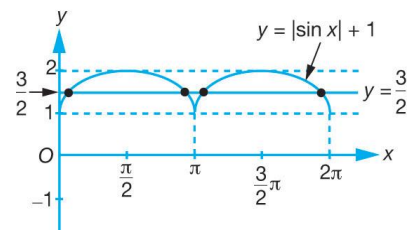

(b) $|2 \sin x| + 2 = 3$

$$|\sin x| + 1 = \frac{3}{2}$$

Sketch the straight line $y = \frac{3}{2}$

(c) Number of solutions
 = Number of points of intersection
 = 4

7 (a)

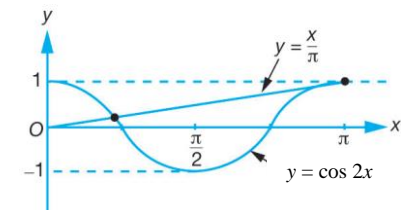

(b) $\pi \cos 2x - x = 0$

$$\pi \cos 2x = x$$

$$\cos 2x = \frac{x}{\pi}$$

Sketch the straight line $y = \frac{x}{\pi}$

Number of solutions
= Number of points of intersection
= 2

UPSKILL 6.4

1 (a) LHS

$$\begin{aligned} &= \frac{\tan^2 \theta}{1 + \tan^2 \theta} \\ &= \frac{\tan^2 \theta}{\sec^2 \theta} \\ &= \frac{\sin^2 \theta}{\cos^2 \theta} \\ &= \frac{\cos^2 \theta}{1} \\ &= \frac{1}{\cos^2 \theta} \\ &= \sin^2 \theta \\ &= \text{RHS} \end{aligned}$$

(b) LHS

$$\begin{aligned} &= \frac{\sec \theta}{\sec \theta - \cos \theta} \\ &= \frac{1}{\cos \theta} \\ &= \frac{1}{\frac{1}{\cos \theta} - \cos \theta} \\ &= \frac{1}{\frac{1 - \cos^2 \theta}{\cos \theta}} \\ &= \frac{1}{\sin^2 \theta} \\ &= \text{cosec}^2 \theta \\ &= \text{RHS} \end{aligned}$$

(c) LHS

$$\begin{aligned} &= \sin \theta \tan \theta + \cos \theta \\ &= \sin \theta \left(\frac{\sin \theta}{\cos \theta} \right) + \cos \theta \\ &= \frac{\sin^2 \theta + \cos^2 \theta}{\cos \theta} \\ &= \frac{1}{\cos \theta} \\ &= \sec \theta \\ &= \text{RHS} \end{aligned}$$

$$\begin{aligned} \text{(d) LHS} &= \tan \theta + \cot \theta \\ &= \frac{\sin \theta}{\cos \theta} + \frac{\cos \theta}{\sin \theta} \\ &= \frac{\sin^2 \theta + \cos^2 \theta}{\sin \theta \cos \theta} \\ &= \frac{1}{\sin \theta \cos \theta} \\ &= \text{cosec } \theta \sec \theta \\ &= \text{RHS} \end{aligned}$$

(e) LHS

$$\begin{aligned} &= (\sin \theta + \cos \theta)^2 + (\sin \theta - \cos \theta)^2 \\ &= \sin^2 \theta + \cos^2 \theta + 2 \sin \theta \cos \theta + \\ &\quad \sin^2 \theta + \cos^2 \theta - 2 \sin \theta \cos \theta \\ &= 1 + 1 \\ &= 2 \\ &= \text{RHS} \end{aligned}$$

(f) LHS

$$\begin{aligned} &= \frac{\text{cosec } \theta}{\text{cosec } \theta - \sin \theta} \\ &= \frac{1}{\frac{1}{\sin \theta} - \sin \theta} \\ &= \frac{1}{\frac{1 - \sin^2 \theta}{\sin \theta}} \\ &= \frac{1}{\cos^2 \theta} \\ &= \sec^2 \theta \\ &= \text{RHS} \end{aligned}$$

(g) LHS

$$\begin{aligned} &= \frac{\sin \theta}{\text{cosec } \theta - \cot \theta} \\ &= \frac{\sin \theta}{\frac{1}{\sin \theta} - \frac{\cos \theta}{\sin \theta}} \\ &= \frac{\sin \theta}{\frac{1 - \cos \theta}{\sin \theta}} \\ &= \frac{\sin^2 \theta}{1 - \cos \theta} \\ &= \frac{1 - \cos^2 \theta}{1 - \cos \theta} \end{aligned}$$

$$\begin{aligned}
&= \frac{(1 + \cos \theta)(1 - \cos \theta)}{1 - \cos \theta} \\
&= 1 + \cos \theta \\
&= \text{RHS}
\end{aligned}$$

(h) LHS

$$\begin{aligned}
&= \frac{1 - \sin \theta}{\cos \theta} + \frac{\cos \theta}{1 - \sin \theta} \\
&= \frac{(1 - \sin \theta)^2 + \cos^2 \theta}{\cos \theta (1 - \sin \theta)} \\
&= \frac{1 - 2\sin \theta + \sin^2 \theta + \cos^2 \theta}{\cos \theta (1 - \sin \theta)} \\
&= \frac{1 - 2\sin \theta + 1}{\cos \theta (1 - \sin \theta)} \\
&= \frac{2 - 2\sin \theta}{\cos \theta (1 - \sin \theta)} \\
&= \frac{2(1 - \sin \theta)}{\cos \theta (1 - \sin \theta)} \\
&= \frac{2}{\cos \theta} \\
&= 2 \sec \theta \\
&= \text{RHS}
\end{aligned}$$

(i) LHS

$$\begin{aligned}
&= \cot^2 \theta - \cos^2 \theta \\
&= \frac{\cos^2 \theta}{\sin^2 \theta} - \cos^2 \theta \\
&= \frac{\cos^2 \theta - \cos^2 \theta \sin^2 \theta}{\sin^2 \theta} \\
&= \frac{\cos^2 \theta (1 - \sin^2 \theta)}{\sin^2 \theta} \\
&= \frac{\cos^2 \theta}{\sin^2 \theta} \times \frac{\cos^2 \theta}{1} \\
&= \cos^2 \theta \cot^2 \theta \\
&= \text{RHS}
\end{aligned}$$

(j) LHS

$$\begin{aligned}
&= \frac{1}{1 + \cos \theta} + \frac{1}{1 - \cos \theta} \\
&= \frac{1 - \cos \theta + 1 + \cos \theta}{(1 + \cos \theta)(1 - \cos \theta)} \\
&= \frac{2}{1 - \cos^2 \theta} \\
&= \frac{2}{\sin^2 \theta} \\
&= 2 \operatorname{cosec}^2 \theta \\
&= \text{RHS}
\end{aligned}$$

(k) LHS

$$\begin{aligned}
&= \frac{1 - \tan^2 \theta}{1 + \tan^2 \theta} \\
&= \frac{1 - \tan^2 \theta}{\sec^2 \theta} \\
&= \frac{1 - \frac{\sin^2 \theta}{\cos^2 \theta}}{\frac{1}{\cos^2 \theta}} \\
&= \frac{\cos^2 \theta - \sin^2 \theta}{\cos^2 \theta} \\
&= \frac{1}{\cos^2 \theta} \\
&= \cos^2 \theta - \sin^2 \theta \\
&= \text{RHS}
\end{aligned}$$

(l) LHS

$$\begin{aligned}
&= \sec^2 \theta + \cot^2 \theta \\
&= 1 + \tan^2 \theta + \operatorname{cosec}^2 \theta - 1 \\
&= \tan^2 \theta + \operatorname{cosec}^2 \theta \\
&= \text{RHS}
\end{aligned}$$

UPSKILL 6.5

1 (a) $\sin 34^\circ \cos 46^\circ + \cos 34^\circ \sin 46^\circ$

$$\begin{aligned}
&= \sin (34^\circ + 46^\circ) \\
&= \sin 80^\circ
\end{aligned}$$

(b) $\sin 53^\circ \cos 23^\circ - \cos 53^\circ \sin 23^\circ$

$$\begin{aligned}
&= \sin (53^\circ - 23^\circ) \\
&= \sin 30^\circ
\end{aligned}$$

(c) $\cos 63^\circ \cos 48^\circ + \sin 63^\circ \sin 48^\circ$

$$\begin{aligned}
&= \cos (63^\circ - 48^\circ) \\
&= \cos 15^\circ
\end{aligned}$$

(d) $\cos 65^\circ \cos 35^\circ - \sin 65^\circ \sin 35^\circ$

$$\begin{aligned}
&= \cos (65^\circ + 35^\circ) \\
&= \cos 100^\circ
\end{aligned}$$

(e) $\frac{\tan 27^\circ + \tan 78^\circ}{1 - \tan 27^\circ \tan 78^\circ}$

$$\begin{aligned}
&= \tan (27^\circ + 78^\circ) \\
&= \tan 105^\circ
\end{aligned}$$

$$\begin{aligned} \text{(f)} \quad & \frac{\tan 92^\circ - \tan 26^\circ}{1 + \tan 92^\circ \tan 26^\circ} \\ &= \tan (92^\circ - 26^\circ) \\ &= \tan 66^\circ \end{aligned}$$

$$\begin{aligned} \text{2 (a)} \quad & 2 \sin 51^\circ \cos 51^\circ \\ &= \sin 2(51^\circ) \\ &= \sin 102^\circ \end{aligned}$$

$$\begin{aligned} \text{(b)} \quad & \cos^2 62^\circ - \sin^2 62^\circ \\ &= \cos 2(62^\circ) \\ &= \cos 124^\circ \end{aligned}$$

$$\begin{aligned} \text{(c)} \quad & 2 \cos^2 110^\circ - 1 \\ &= \cos 2(110^\circ) \\ &= \cos 220^\circ \end{aligned}$$

$$\begin{aligned} \text{(d)} \quad & 1 - 2 \sin^2 85^\circ \\ &= \cos 2(85^\circ) \\ &= \cos 170^\circ \end{aligned}$$

$$\begin{aligned} \text{(e)} \quad & \frac{2 \tan 76^\circ}{1 - \tan^2 76^\circ} \\ &= \tan 2(76^\circ) \\ &= \tan 152^\circ \end{aligned}$$

3

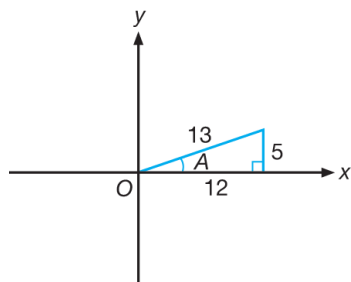

$$\sin A = \frac{5}{13}, \quad \cos A = \frac{12}{13}, \quad \tan A = \frac{5}{12}$$

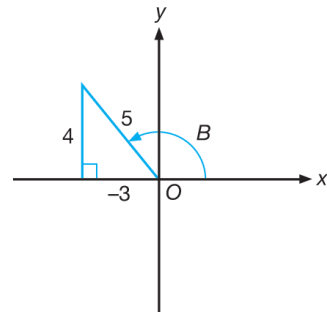

$$\sin B = \frac{4}{5}, \quad \cos B = -\frac{3}{5}, \quad \tan B = -\frac{4}{3}$$

$$\begin{aligned} \text{(a)} \quad & \sin (A + B) \\ &= \sin A \cos B + \cos A \sin B \\ &= \left(\frac{5}{13}\right)\left(-\frac{3}{5}\right) + \left(\frac{12}{13}\right)\left(\frac{4}{5}\right) \\ &= \frac{33}{65} \end{aligned}$$

$$\begin{aligned} \text{(b)} \quad & \cos (A + B) \\ &= \cos A \cos B - \sin A \sin B \\ &= \left(\frac{12}{13}\right)\left(-\frac{3}{5}\right) - \left(\frac{5}{13}\right)\left(\frac{4}{5}\right) \\ &= -\frac{56}{65} \end{aligned}$$

$$\begin{aligned} \text{(c)} \quad & \tan (A + B) \\ &= \frac{\tan A + \tan B}{1 - \tan A \tan B} \\ &= \frac{\frac{5}{12} + \left(-\frac{4}{3}\right)}{1 - \left(\frac{5}{12}\right)\left(-\frac{4}{3}\right)} \\ &= \frac{-\frac{11}{12}}{\frac{14}{9}} = -\frac{33}{56} \end{aligned}$$

4

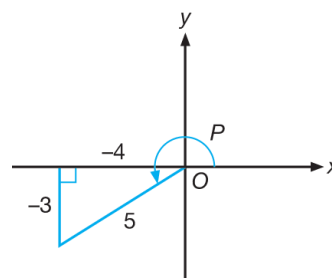

$$\sin P = -\frac{3}{5}, \quad \cos P = -\frac{4}{5}, \quad \tan P = \frac{3}{4}$$

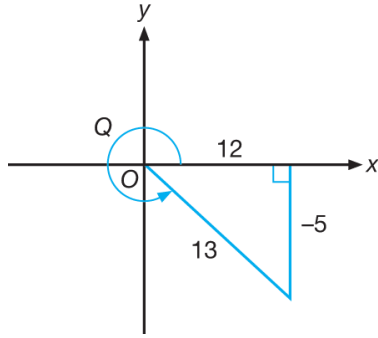

$$\sin Q = -\frac{5}{13}, \quad \cos Q = \frac{12}{13}, \quad \tan Q = -\frac{5}{12}$$

(a) $\sin(P - Q)$

$$\begin{aligned} &= \sin P \cos Q - \cos P \sin Q \\ &= \left(-\frac{3}{5}\right)\left(\frac{12}{13}\right) - \left(-\frac{4}{5}\right)\left(-\frac{5}{13}\right) \\ &= -\frac{56}{65} \end{aligned}$$

(b) $\cos(P - Q)$

$$\begin{aligned} &= \cos P \cos Q + \sin P \sin Q \\ &= \left(-\frac{4}{5}\right)\left(\frac{12}{13}\right) + \left(-\frac{3}{5}\right)\left(-\frac{5}{13}\right) \\ &= -\frac{33}{65} \end{aligned}$$

(c) $\tan(P - Q)$

$$\begin{aligned} &= \frac{\tan P - \tan Q}{1 + \tan P \tan Q} \\ &= \frac{\frac{3}{4} - \left(-\frac{5}{12}\right)}{1 + \left(\frac{3}{4}\right)\left(-\frac{5}{12}\right)} \\ &= \frac{\frac{7}{6}}{\frac{11}{16}} = \frac{56}{33} \end{aligned}$$

5

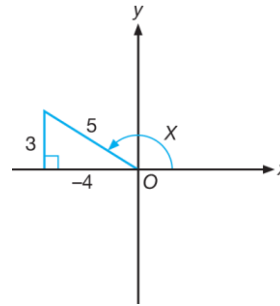

$$\sin X = \frac{3}{5}, \quad \cos X = -\frac{4}{5}, \quad \tan X = -\frac{3}{4}$$

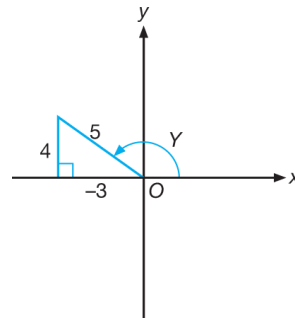

$$\sin Y = \frac{4}{5}, \quad \cos Y = -\frac{3}{5}, \quad \tan Y = -\frac{4}{3}$$

(a) $\cos 2X = 1 - 2\sin^2 X = 1 - 2\left(\frac{3}{5}\right)^2 = \frac{7}{25}$

(b) $\sin(2X + Y)$

$$\begin{aligned} &= \sin 2X \cos Y + \cos 2X \sin Y \\ &= 2\sin X \cos X (\cos Y) + \cos 2X \sin Y \\ &= 2\left(\frac{3}{5}\right)\left(-\frac{4}{5}\right)\left(-\frac{3}{5}\right) + \frac{7}{25}\left(\frac{4}{5}\right) \\ &= \frac{72}{125} + \frac{28}{125} \\ &= \frac{4}{5} \end{aligned}$$

6

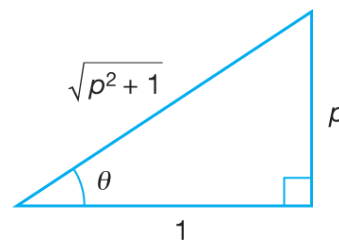

(a) $\sin \theta = \frac{p}{\sqrt{p^2 + 1}}$

$$(b) \cos(-\theta) = \cos \theta = \frac{1}{\sqrt{p^2+1}}$$

$$(c) \cos 2\theta = 1 - 2\sin^2 \theta$$

$$= \frac{p^2+1-2p^2}{p^2+1}$$

$$= \frac{1-p^2}{1+p^2}$$

7

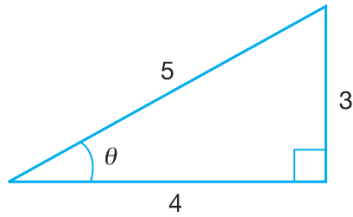

$$(a) \cos 2\theta = 2\cos^2 \theta - 1$$

$$= 2\left(\frac{4}{5}\right)^2 - 1$$

$$= \frac{7}{25}$$

$$(b) \sec(180^\circ - \theta)$$

$$= \frac{1}{\cos(180^\circ - \theta)}$$

$$= \frac{1}{\cos 180^\circ \cos \theta + \sin 180^\circ \sin \theta}$$

$$= \frac{1}{-\cos \theta + 0}$$

$$= -\frac{1}{\cos \theta}$$

$$= -\frac{5}{4}$$

$$(c) \tan(90^\circ - \theta)$$

$$= \cot \theta$$

$$= \frac{1}{\tan \theta}$$

$$= \frac{1}{\frac{3}{4}}$$

$$= \frac{4}{3}$$

$$8 (a) \cos 2A = -\frac{7}{25}$$

$$1 - 2\sin^2 A = -\frac{7}{25}$$

$$2\sin^2 A = \frac{32}{25}$$

$$\sin^2 A = \frac{16}{25}$$

$$\sin A = \frac{4}{5}$$

(b)

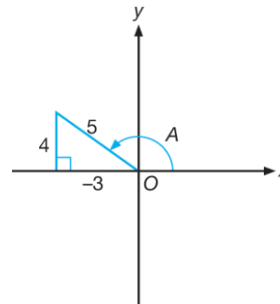

$$\cos A = -\frac{3}{5}$$

$$(c) \tan A = -\frac{4}{3}$$

9 (a) LHS

$$= (\sin \theta + \cos \theta)^2$$

$$= \sin^2 \theta + \cos^2 \theta + 2\sin \theta \cos \theta$$

$$= 1 + \cos 2\theta$$

$$= \text{RHS}$$

(b) LHS

$$= \cos^4 \theta - \sin^4 \theta$$

$$= (\cos^2 \theta + \sin^2 \theta)(\cos^2 \theta - \sin^2 \theta)$$

$$= (1)(\cos 2\theta)$$

$$= \cos 2\theta$$

$$= \text{RHS}$$

(c) LHS

$$= \tan \theta + \cot \theta$$

$$= \frac{\sin \theta}{\cos \theta} + \frac{\cos \theta}{\sin \theta}$$

$$= \frac{\sin^2 \theta + \cos^2 \theta}{\sin \theta \cos \theta}$$

$$= \frac{1}{\sin \theta \cos \theta}$$

$$= \frac{2}{2 \sin \theta \cos \theta}$$

$$\begin{aligned}
&= \frac{2}{\sin 2\theta} \\
&= 2 \operatorname{cosec} 2\theta \\
&= \text{RHS}
\end{aligned}$$

(d) LHS

$$\begin{aligned}
&= \frac{2 \sin \theta}{2 \cos \theta - \sec \theta} \\
&= \frac{2 \sin \theta}{2 \cos \theta - \frac{1}{\cos \theta}} \\
&= \frac{2 \sin \theta}{\frac{2 \cos^2 \theta - 1}{\cos \theta}} \\
&= \frac{2 \sin \theta \cos \theta}{\cos 2\theta} \\
&= \frac{\sin 2\theta}{\cos 2\theta} \\
&= \tan 2\theta \\
&= \text{RHS}
\end{aligned}$$

(e) LHS

$$\begin{aligned}
&= \frac{1 - \tan^2 \theta}{1 + \tan^2 \theta} \\
&= \frac{1 - \frac{\sin^2 \theta}{\cos^2 \theta}}{\sec^2 \theta} \\
&= \frac{\frac{\cos^2 \theta - \sin^2 \theta}{\cos^2 \theta}}{\frac{1}{\cos^2 \theta}} \\
&= \cos^2 \theta \\
&= \text{RHS}
\end{aligned}$$

10 (a) LHS

$$\begin{aligned}
&= \frac{\sin 2\theta}{1 - \cos 2\theta} \\
&= \frac{2 \sin \theta \cos \theta}{1 - (1 - 2 \sin^2 \theta)} \\
&= \frac{2 \sin \theta \cos \theta}{2 \sin^2 \theta} \\
&= \frac{\cos \theta}{\sin \theta} \\
&= \cot \theta \\
&= \text{RHS}
\end{aligned}$$

(b) LHS

$$= \frac{1 + \cos 2\theta}{1 - \cos 2\theta}$$

$$\begin{aligned}
&= \frac{1 + (2 \cos^2 \theta - 1)}{1 - (1 - 2 \sin^2 \theta)} \\
&= \frac{2 \cos^2 \theta}{2 \sin^2 \theta} \\
&= \frac{\cos^2 \theta}{\sin^2 \theta} \\
&= \cot^2 \theta \\
&= \text{RHS}
\end{aligned}$$

(c) LHS

$$\begin{aligned}
&= \frac{\sin \theta + \sin 2\theta}{1 + \cos \theta + \cos 2\theta} \\
&= \frac{\sin \theta + 2 \sin \theta \cos \theta}{1 + \cos \theta + 2 \cos^2 \theta - 1} \\
&= \frac{\sin \theta (1 + 2 \cos \theta)}{\cos \theta (1 + 2 \cos \theta)} \\
&= \frac{\sin \theta}{\cos \theta} \\
&= \tan \theta \\
&= \text{RHS}
\end{aligned}$$

11 (a) LHS

$$\begin{aligned}
&= \frac{2(\cos \theta + \sin \theta)}{\sin 2\theta + \cos 2\theta + 1} \\
&= \frac{2(\cos \theta + \sin \theta)}{\sin 2\theta + (2 \cos^2 \theta - 1) + 1} \\
&= \frac{2(\cos \theta + \sin \theta)}{2 \sin \theta \cos \theta + 2 \cos^2 \theta} \\
&= \frac{2(\cos \theta + \sin \theta)}{2 \cos \theta (\sin \theta + \cos \theta)} \\
&= \frac{1}{\cos \theta} \\
&= \sec \theta \\
&= \text{RHS}
\end{aligned}$$

(b) LHS

$$\begin{aligned}
&= \frac{\sin \theta}{1 - \cos 2\theta} + \frac{\cos \theta}{1 + \cos 2\theta} \\
&= \frac{\sin \theta}{1 - (1 - 2 \sin^2 \theta)} + \frac{\cos \theta}{1 + (2 \cos^2 \theta - 1)} \\
&= \frac{\sin \theta}{2 \sin^2 \theta} + \frac{\cos \theta}{2 \cos^2 \theta} \\
&= \frac{1}{2 \sin \theta} + \frac{1}{2 \cos \theta} \\
&= \frac{\cos \theta + \sin \theta}{2 \sin \theta \cos \theta} \\
&= \frac{\cos \theta + \sin \theta}{\sin 2\theta}
\end{aligned}$$

$$= \text{RHS}$$

(c) LHS

$$\begin{aligned} &= \tan 2\theta (2 \cos \theta - \sec \theta) \\ &= \frac{\sin 2\theta}{\cos 2\theta} \left(2 \cos \theta - \frac{1}{\cos \theta} \right) \\ &= \frac{\sin 2\theta}{\cos 2\theta} \left(\frac{2 \cos^2 \theta - 1}{\cos \theta} \right) \\ &= \frac{2 \sin \theta \cos \theta}{\cos 2\theta} \left(\frac{\cos 2\theta}{\cos \theta} \right) \\ &= 2 \sin \theta \\ &= \text{RHS} \end{aligned}$$

12 (a) LHS

$$\begin{aligned} &= \frac{\cos(A+B)}{\sin A \cos B} \\ &= \frac{\cos A \cos B - \sin A \sin B}{\sin A \cos B} \\ &= \frac{\cos A \cos B}{\sin A \cos B} - \frac{\sin A \sin B}{\sin A \cos B} \\ &= \frac{\cos A}{\sin A} - \frac{\sin B}{\cos B} \\ &= \cot A - \tan B \\ &= \text{RHS} \end{aligned}$$

(b) LHS

$$\begin{aligned} &= \frac{\cos(A-B) - \cos(A+B)}{\sin(A+B) + \sin(A-B)} \\ &= \frac{\cos A \cos B + \sin A \sin B - (\cos A \cos B - \sin A \sin B)}{\sin A \cos B + \cos A \sin B + \sin A \cos B - \cos A \sin B} \\ &= \frac{\sin A \sin B + \sin A \sin B}{\sin A \cos B + \sin A \cos B} \\ &= \frac{2 \sin A \sin B}{2 \sin A \cos B} \\ &= \frac{\sin B}{\cos B} \\ &= \tan B \\ &= \text{RHS} \end{aligned}$$

13 (a) LHS

$$\begin{aligned} &= \frac{1 - \cos \theta}{\sin \theta} \\ &= \frac{1 - \left(1 - 2 \sin^2 \frac{\theta}{2} \right)}{2 \sin \frac{\theta}{2} \cos \frac{\theta}{2}} \end{aligned}$$

$$\begin{aligned} &= \frac{2 \sin^2 \frac{\theta}{2}}{2 \sin \frac{\theta}{2} \cos \frac{\theta}{2}} \\ &= \frac{\sin \frac{\theta}{2}}{\cos \frac{\theta}{2}} \\ &= \tan \frac{\theta}{2} \end{aligned}$$

(b) LHS

$$\begin{aligned} &= \frac{1 - \cos \theta}{1 + \cos \theta} \\ &= \frac{1 - \left(1 - 2 \sin^2 \frac{\theta}{2} \right)}{1 + \left(2 \cos^2 \frac{\theta}{2} - 1 \right)} \\ &= \frac{2 \sin^2 \frac{\theta}{2}}{2 \cos^2 \frac{\theta}{2}} \\ &= \tan^2 \frac{\theta}{2} \\ &= \text{RHS} \end{aligned}$$

UPSKILL 6.6a

1 (a)

$$\cot \theta = -2 \cos \theta$$

$$\frac{\cos \theta}{\sin \theta} = -2 \cos \theta$$

$$\cos \theta = -2 \sin \theta \cos \theta$$

$$\cos \theta + 2 \sin \theta \cos \theta = 0$$

$$\cos \theta (1 + 2 \sin \theta) = 0$$

$$\cos \theta = 0 \text{ or } \sin \theta = -\frac{1}{2}$$

When $\cos \theta = 0$,

$$\theta = 90^\circ, 270^\circ$$

When $\sin \theta = -\frac{1}{2}$,

$$\text{Basic } \angle = 30^\circ$$

$$\theta = 210^\circ, 330^\circ$$

(b)

$$3 \sin \theta = \tan \theta$$

$$3 \sin \theta = \frac{\sin \theta}{\cos \theta}$$

$$3 \sin \theta \cos \theta = \sin \theta$$

$$3 \sin \theta \cos \theta - \sin \theta = 0$$

$$\sin \theta (3 \cos \theta - 1) = 0$$

$$\sin \theta = 0 \text{ or } \cos \theta = \frac{1}{3}$$

$$\text{When } \sin \theta = 0,$$

$$\theta = 0^\circ, 180^\circ, 360^\circ$$

$$\text{When } \cos \theta = \frac{1}{3},$$

$$\text{Basic } \angle = 70.53^\circ$$

$$\theta = 70.53^\circ, 289.47^\circ$$

$$(c) \quad 3 \sec \theta = 4 \cos \theta$$

$$\frac{3}{\cos \theta} = 4 \cos \theta$$

$$3 = 4 \cos^2 \theta$$

$$\cos^2 \theta = \frac{3}{4}$$

$$\cos \theta = \pm \frac{\sqrt{3}}{2}$$

$$\theta = 30^\circ, 150^\circ, 210^\circ, 330^\circ$$

$$(d) \quad 16 \tan \theta = \cot \theta$$

$$16 \tan \theta = \frac{1}{\tan \theta}$$

$$\tan^2 \theta = \frac{1}{16}$$

$$\tan \theta = \pm \frac{1}{4}$$

$$\theta = 14.04^\circ, 165.96^\circ, 194.04^\circ, 345.96^\circ$$

$$2 (a) \quad 3 \sin^2 \theta - 2 \sin \theta - 1 = 0$$

$$(\sin \theta - 1)(3 \sin \theta + 1) = 0$$

$$\sin \theta = 1 \text{ or } \sin \theta = -\frac{1}{3}$$

$$\text{When } \sin \theta = 1,$$

$$\theta = 90^\circ$$

$$\text{When } \sin \theta = -\frac{1}{3},$$

$$\text{Basic } \angle = 19.47^\circ$$

$$\theta = 199.47^\circ \text{ or } 340.53^\circ$$

$$(b) \quad 2 \sin \theta = \operatorname{cosec} \theta + 1$$

$$2 \sin \theta = \frac{1}{\sin \theta} + 1$$

$$2 \sin^2 \theta = 1 + \sin \theta$$

$$2 \sin^2 \theta - \sin \theta - 1 = 0$$

$$(\sin \theta - 1)(2 \sin \theta + 1) = 0$$

$$\sin \theta = 1 \text{ or } \sin \theta = -\frac{1}{2}$$

$$\text{When } \sin \theta = 1,$$

$$\theta = 90^\circ$$

$$\text{When } \sin \theta = -\frac{1}{2},$$

$$\text{Basic } \angle = 30^\circ$$

$$\theta = 210^\circ, 330^\circ$$

$$(c) \quad 3 \cos^2 \theta + \sin \theta = 1$$

$$3(1 - \sin^2 \theta) + \sin \theta - 1 = 0$$

$$3 - 3 \sin^2 \theta + \sin \theta - 1 = 0$$

$$3 \sin^2 \theta - \sin \theta - 2 = 0$$

$$(\sin \theta - 1)(3 \sin \theta + 2) = 0$$

$$\sin \theta = 1 \text{ or } \sin \theta = -\frac{2}{3}$$

$$\text{When } \sin \theta = 1,$$

$$\theta = 90^\circ$$

$$\text{When } \sin \theta = -\frac{2}{3},$$

$$\text{Basic } \angle = 41.81^\circ$$

$$\theta = 221.81^\circ, 318.19^\circ$$

$$(d) \quad 5 \sin^2 \theta = 2(1 + \cos \theta)$$

$$5(1 - \cos^2 \theta) = 2 + 2 \cos \theta$$

$$5 - 5 \cos^2 \theta - 2 \cos \theta - 2 = 0$$

$$5 \cos^2 \theta + 2 \cos \theta - 3 = 0$$

$$(5 \cos \theta - 3)(\cos \theta + 1) = 0$$

$$\cos \theta = \frac{3}{5} \text{ or } \cos \theta = -1$$

$$\text{When } \cos \theta = \frac{3}{5},$$

$$\text{Basic } \angle = 53.13^\circ$$

$$\theta = 53.13^\circ \text{ or } 306.87^\circ$$

$$\text{When } \cos \theta = -1,$$

$$\theta = 180^\circ$$

$$(e) \quad 2 \sec \theta = 1 + \cos \theta$$

$$\frac{2}{\cos \theta} = 1 + \cos \theta$$

$$2 = \cos \theta + \cos^2 \theta$$

$$\cos^2 \theta + \cos \theta - 2 = 0$$

$$(\cos \theta - 1)(\cos \theta + 2) = 0$$

$$\cos \theta = 1 \text{ or } \cos \theta = -2$$

$\cos \theta = -2$ does not have solution
because the minimum value of
 $\cos \theta = -1$.

When $\cos \theta = 1$,

$$\theta = 0^\circ, 360^\circ$$

(f) $2 \cot \theta = \tan \theta + 1$

$$\frac{2}{\tan \theta} = \tan \theta + 1$$

$$2 = \tan^2 \theta + \tan \theta$$

$$\tan^2 \theta + \tan \theta - 2 = 0$$

$$(\tan \theta - 1)(\tan \theta + 2) = 0$$

$$\tan \theta = 1 \text{ or } \tan \theta = -2$$

When $\tan \theta = 1$,

$$\theta = 45^\circ, 225^\circ$$

When $\tan \theta = -2$,

$$\text{Basic } \angle = 63.43^\circ$$

$$\theta = 116.57^\circ, 296.57^\circ$$

(g) $3 \sin \theta + 1 = 2 \operatorname{cosec} \theta$

$$3 \sin \theta + 1 = \frac{2}{\sin \theta}$$

$$3 \sin^2 \theta + \sin \theta - 2 = 0$$

$$(3 \sin \theta - 2)(\sin \theta + 1) = 0$$

$$\sin \theta = \frac{2}{3} \text{ or } \sin \theta = -1$$

When $\sin \theta = \frac{2}{3}$,

$$\text{Basic } \angle = 41.81^\circ$$

$$\theta = 41.81^\circ, 138.19^\circ$$

When $\sin \theta = -1$,

$$\theta = 270^\circ$$

3 (a) $3 \sec^2 \theta = 5(1 + \tan \theta)$

$$3(1 + \tan^2 \theta) = 5 + 5 \tan \theta$$

$$3 + 3 \tan^2 \theta - 5 \tan \theta - 5 = 0$$

$$3 \tan^2 \theta - 5 \tan \theta - 2 = 0$$

$$(\tan \theta - 2)(3 \tan \theta + 1) = 0$$

$$\tan \theta = 2 \text{ or } \tan \theta = -\frac{1}{3}$$

When $\tan \theta = 2$,

$$\text{Basic } \angle = 63.43^\circ$$

$$\theta = 63.43^\circ, 243.43^\circ$$

When $\tan \theta = -\frac{1}{3}$,

$$\text{Basic } \angle = 18.43^\circ$$

$$\theta = 161.57^\circ, 341.57^\circ$$

(b) $2 \cot^2 \theta + 8 = 7 \operatorname{cosec} \theta$

$$2(\operatorname{cosec}^2 \theta - 1) + 8 - 7 \operatorname{cosec} \theta = 0$$

$$2 \operatorname{cosec}^2 \theta - 2 + 8 - 7 \operatorname{cosec} \theta = 0$$

$$2 \operatorname{cosec}^2 \theta - 7 \operatorname{cosec} \theta + 6 = 0$$

$$(\operatorname{cosec} \theta - 2)(2 \operatorname{cosec} \theta - 3) = 0$$

$$\operatorname{cosec} \theta = 2 \text{ or } \operatorname{cosec} \theta = \frac{3}{2}$$

When $\operatorname{cosec} \theta = 2$,

$$\frac{1}{\sin \theta} = 2$$

$$\sin \theta = \frac{1}{2}$$

$$\theta = 30^\circ, 150^\circ$$

When $\operatorname{cosec} \theta = \frac{3}{2}$,

$$\frac{1}{\sin \theta} = \frac{3}{2}$$

$$\sin \theta = \frac{2}{3}$$

$$\text{Basic } \angle = 41.81^\circ$$

$$\theta = 41.81^\circ, 138.19^\circ$$

4 (a) $4 \sin \theta = \sec \theta$

$$4 \sin \theta = \frac{1}{\cos \theta}$$

$$2(2 \sin \theta \cos \theta) = 1$$

$$2 \sin 2\theta = 1$$

$$\sin 2\theta = \frac{1}{2}$$

$$\text{Basic } \angle = 30^\circ$$

$$2\theta = 30^\circ, 150^\circ, 390^\circ, 510^\circ$$

$$\theta = 15^\circ, 75^\circ, 195^\circ, 255^\circ$$

(b) $\sin 2\theta + \sin \theta = 0$

$$2 \sin \theta \cos \theta + \sin \theta = 0$$

$$\sin \theta (2 \cos \theta + 1) = 0$$

$$\sin \theta = 0 \text{ or } \cos \theta = -\frac{1}{2}$$

When $\sin \theta = 0$,

$$\theta = 0^\circ, 180^\circ, 360^\circ$$

$$\text{When } \cos \theta = -\frac{1}{2}$$

$$\text{Basic } \angle = 60^\circ$$

$$\theta = 120^\circ, 240^\circ$$

$$(c) \quad 2 \sin \theta = \tan \theta$$

$$2 \sin \theta = \frac{\sin \theta}{\cos \theta}$$

$$2 \sin \theta \cos \theta = \sin \theta$$

$$2 \sin \theta \cos \theta - \sin \theta = 0$$

$$\sin \theta (2 \cos \theta - 1) = 0$$

$$\sin \theta = 0 \text{ or } \cos \theta = \frac{1}{2}$$

$$\text{When } \sin \theta = 0,$$

$$\theta = 0^\circ, 180^\circ, 360^\circ$$

$$\text{When } \cos \theta = \frac{1}{2},$$

$$\theta = 60^\circ, 300^\circ$$

$$5 (a) \quad 3 \cos 2\theta + \sin \theta - 2 = 0$$

$$3(1 - 2 \sin^2 \theta) + \sin \theta - 2 = 0$$

$$3 - 6 \sin^2 \theta + \sin \theta - 2 = 0$$

$$6 \sin^2 \theta - \sin \theta - 1 = 0$$

$$(2 \sin \theta - 1)(3 \sin \theta + 2) = 0$$

$$\sin \theta = \frac{1}{2} \text{ or } \sin \theta = -\frac{2}{3}$$

$$\text{When } \sin \theta = \frac{1}{2},$$

$$\theta = 30^\circ, 150^\circ$$

$$\text{When } \sin \theta = -\frac{2}{3},$$

$$\text{Basic } \angle = 19.47^\circ$$

$$\theta = 199.47^\circ, 340.53^\circ$$

$$(b) \quad 3 \cos 2\theta + 8 \sin \theta + 5 = 0$$

$$3(1 - 2 \sin^2 \theta) + 8 \sin \theta + 5 = 0$$

$$3 - 6 \sin^2 \theta + 8 \sin \theta + 5 = 0$$

$$6 \sin^2 \theta - 8 \sin \theta - 8 = 0$$

$$3 \sin^2 \theta - 4 \sin \theta - 4 = 0$$

$$(\sin \theta - 2)(3 \sin \theta + 2) = 0$$

$$\sin \theta = 2 \text{ or } \sin \theta = -\frac{2}{3}$$

$\sin \theta = 2$ does not have solution because the maximum value of $\sin \theta$ is 1.

$$\sin \theta = -\frac{2}{3}$$

$$\text{Basic } \angle = 41.81^\circ$$

$$\theta = 221.81^\circ \text{ or } 318.19^\circ$$

$$(c) \quad \cos 2\theta + \cos \theta = 0$$

$$2 \cos^2 \theta - 1 + \cos \theta = 0$$

$$2 \cos^2 \theta + \cos \theta - 1 = 0$$

$$(2 \cos \theta - 1)(\cos \theta + 1) = 0$$

$$\cos \theta = \frac{1}{2} \text{ or } \cos \theta = -1$$

$$\text{When } \cos \theta = \frac{1}{2},$$

$$\theta = 60^\circ, 300^\circ$$

$$\text{When } \cos \theta = -1,$$

$$\theta = 180^\circ$$

$$(d) \quad 6 \cos 2\theta - 17 \cos \theta + 12 = 0$$

$$6(2 \cos^2 \theta - 1) - 17 \cos \theta + 12 = 0$$

$$12 \cos^2 \theta - 6 - 17 \cos \theta + 12 = 0$$

$$12 \cos^2 \theta - 17 \cos \theta + 6 = 0$$

$$(4 \cos \theta - 3)(3 \cos \theta - 2) = 0$$

$$\cos \theta = \frac{3}{4} \text{ or } \cos \theta = \frac{2}{3}$$

$$\text{When } \cos \theta = \frac{3}{4},$$

$$\text{Basic } \angle = 41.41^\circ$$

$$\theta = 41.41^\circ, 318.59^\circ$$

$$\text{When } \cos \theta = \frac{2}{3},$$

$$\text{Basic } \angle = 48.19^\circ$$

$$\theta = 48.19^\circ, 311.81^\circ$$

$$6 (a) \quad \cos(\theta + 60^\circ) = \sin \theta$$

$$\cos \theta \cos 60^\circ - \sin \theta \sin 60^\circ = \sin \theta$$

$$\frac{1}{2} \cos \theta - \frac{\sqrt{3}}{2} \sin \theta = \sin \theta$$

$$\frac{1}{2} \cos \theta = \left(1 + \frac{\sqrt{3}}{2}\right) \sin \theta$$

$$(2 + \sqrt{3}) \sin \theta = \cos \theta$$

$$\frac{\sin \theta}{\cos \theta} = \frac{1}{(2 + \sqrt{3})}$$

$$\tan \theta = 0.2679$$

$$\text{Basic } \angle = 15^\circ$$

$$\theta = 15^\circ, 195^\circ$$

$$\begin{aligned}
 \text{(b)} \quad & 2 \cos(\theta + 30^\circ) = \sin \theta \\
 & 2(\cos \theta \cos 30^\circ - \sin \theta \sin 30^\circ) = \sin \theta \\
 & 2\left(\frac{\sqrt{3}}{2} \cos \theta - \frac{1}{2} \sin \theta\right) = \sin \theta \\
 & \sqrt{3} \cos \theta - \sin \theta = \sin \theta \\
 & \sqrt{3} \cos \theta = 2 \sin \theta \\
 & \frac{\sin \theta}{\cos \theta} = \frac{\sqrt{3}}{2} \\
 & \tan \theta = \frac{\sqrt{3}}{2} \\
 & \text{Basic } \angle = 40.89^\circ \\
 & \theta = 40.89^\circ, 220.89^\circ
 \end{aligned}$$

$$\begin{aligned}
 \text{(c)} \quad & 4 \sin(\theta - 30^\circ) = \cos \theta \\
 & 4(\sin \theta \cos 30^\circ - \cos \theta \sin 30^\circ) = \cos \theta \\
 & 4\left(\frac{\sqrt{3}}{2} \sin \theta - \frac{1}{2} \cos \theta\right) = \cos \theta \\
 & 2\sqrt{3} \sin \theta - 2 \cos \theta = \cos \theta \\
 & 2\sqrt{3} \sin \theta = 3 \cos \theta \\
 & \frac{\sin \theta}{\cos \theta} = \frac{3}{2\sqrt{3}} \\
 & \tan \theta = 0.8660 \\
 & \text{Basic } \angle = 40.89^\circ \\
 & \theta = 40.89^\circ, 220.89^\circ
 \end{aligned}$$

UPSKILL 6.6b

1 $I = A \sin 120\pi t$

$$120\pi t = 2\pi$$

$$t = \frac{2\pi}{120\pi}$$

$$t = \frac{1}{60}$$

$$\text{Period} = \frac{1}{60} \text{ second}$$

2 $y = f(x) = 6 + 2 \sin \frac{\pi}{6} t$

$$\frac{\pi}{6} t = 2\pi$$

$$t = 12$$

$$\text{Period} = 12 \text{ hours}$$

Summative Practice 6

1

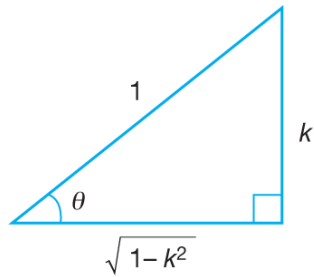

(a) $\tan \theta = \frac{k}{\sqrt{1-k^2}}$

(b) $\sec(-\theta) = \frac{1}{\cos(-\theta)} = \frac{1}{\cos \theta} = \frac{1}{\sqrt{1-k^2}}$

2

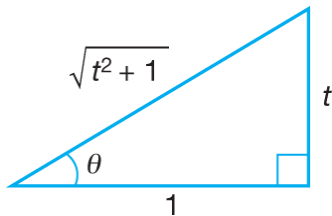

(a) $\cot(-\theta) = \frac{1}{\tan(-\theta)} = -\frac{1}{\tan \theta} = -\frac{1}{t}$

(b) $\cos(90^\circ - \theta) = \sin \theta = \frac{t}{\sqrt{t^2+1}}$

3 (a)

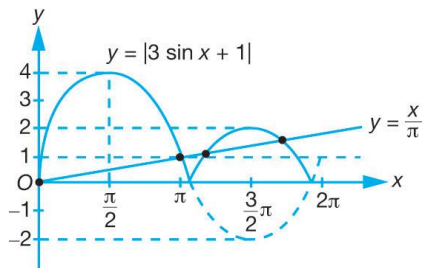

(b) $\pi|3 \sin x + 1| - x = 0$

$$|3 \sin x + 1| = \frac{x}{\pi}$$

Sketch the straight line $y = \frac{x}{\pi}$

Number of solutions
= Number of points of intersection
= 4

4 (a)

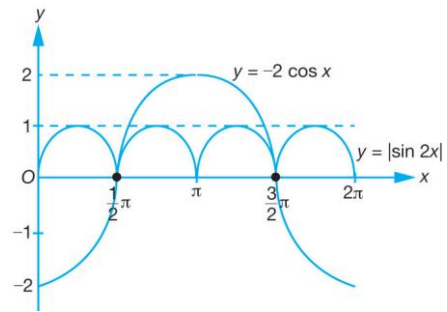

(b) $|\sin 2x| + 2 \cos x = 0$

$$|\sin 2x| = -2 \cos x$$

Sketch the straight line $y = |\sin 2x|$

Number of solutions
= Number of points of intersection
= 2

5 (a)

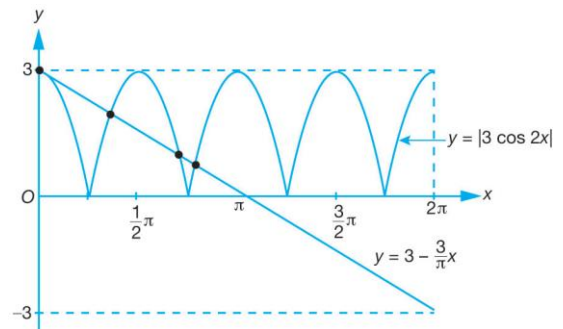

(b) $3 - |3 \cos 2x| = \frac{3}{\pi} x$

$$|3 \cos 2x| = 3 - \frac{3}{\pi} x$$

Sketch the straight line $y = 3 - \frac{3}{\pi} x$

Number of solutions
= Number of points of intersection
= 4

6 (a)

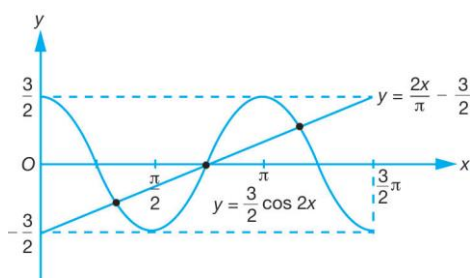

(b) $\left(\frac{4}{3\pi}\right)x - \cos 2x = 1$

$$\cos 2x = \left(\frac{4}{3\pi}\right)x - 1$$

$$\frac{3}{2} \cos 2x = \frac{3}{2} \left[\left(\frac{4}{3\pi}\right)x - 1 \right]$$

$$\frac{3}{2} \cos 2x = \left(\frac{2}{\pi}\right)x - \frac{3}{2}$$

Sketch the straight line $y = \left(\frac{2}{\pi}\right)x - \frac{3}{2}$

Number of solutions
= Number of points of intersection
= 3

7 (a)

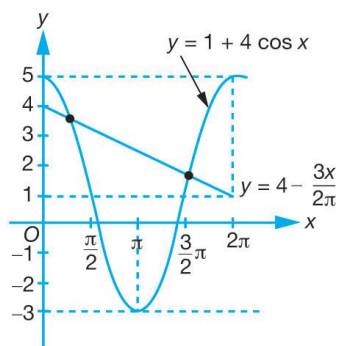

(b) $4\pi \cos x = 3\pi - \frac{3}{2}x$

$$4 \cos x = 3 - \frac{3}{2} \left(\frac{x}{\pi}\right)$$

$$1 + 4 \cos x = 4 - \frac{3}{2} \left(\frac{x}{\pi}\right)$$

Sketch the straight line $y = 4 - \frac{3x}{2\pi}$

Number of solutions
= Number of points of intersection
= 2

8 (a)

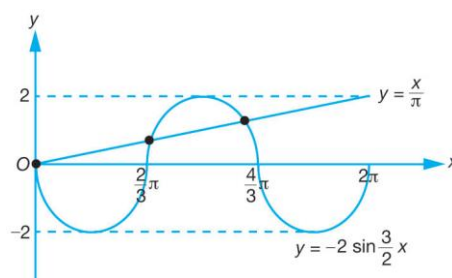

(b) $\frac{x}{\pi} + 2 \sin \frac{3}{2}x = 0$

$$\frac{x}{\pi} = -2 \sin \frac{3}{2}x$$

Sketch the straight line $y = \frac{x}{\pi}$

Number of solutions
= Number of points of intersection
= 3

9 (a)

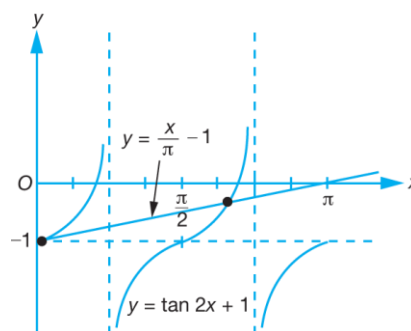

(b) $\pi \tan 2x - x = 0$

$$\pi \tan 2x = x$$

$$\tan 2x = \frac{x}{\pi}$$

$$\tan 2x - 1 = \frac{x}{\pi} - 1$$

Sketch the straight line $y = \frac{x}{\pi} - 1$

Number of solutions
= Number of points of intersection
= 2

10 (a) LHS

$$\begin{aligned} &= (\tan x + \sec x)^2 \\ &= \left(\frac{\sin x}{\cos x} + \frac{1}{\cos x} \right)^2 \\ &= \left(\frac{\sin x + 1}{\cos x} \right)^2 \\ &= \frac{(\sin x + 1)^2}{\cos^2 x} \\ &= \frac{(\sin x + 1)^2}{1 - \sin^2 x} \\ &= \frac{(1 + \sin x)(1 + \sin x)}{(1 + \sin x)(1 - \sin x)} \\ &= \frac{1 + \sin x}{1 - \sin x} \\ &= \text{RHS} \end{aligned}$$

(b) LHS

$$\begin{aligned} &= \sin x + \operatorname{cosec} x \cos^2 x \\ &= \sin x + \frac{\cos^2 x}{\sin x} \\ &= \frac{\sin^2 x + \cos^2 x}{\sin x} \\ &= \frac{1}{\sin x} \\ &= \operatorname{cosec} x \\ &= \text{RHS} \end{aligned}$$

(c) LHS

$$\begin{aligned} &= \frac{\cos x}{1 - \tan x} - \frac{\sin x}{\cot x - 1} \\ &= \frac{\cos x}{1 - \frac{\sin x}{\cos x}} - \frac{\sin x}{\frac{\cos x}{\sin x} - 1} \\ &= \frac{\cos x}{\frac{\cos x - \sin x}{\cos x}} - \frac{\sin x}{\frac{\cos x - \sin x}{\sin x}} \\ &= \frac{\cos^2 x}{\cos x - \sin x} - \frac{\sin^2 x}{\cos x - \sin x} \\ &= \frac{\cos^2 x - \sin^2 x}{\cos x - \sin x} \\ &= \frac{(\cos x + \sin x)(\cos x - \sin x)}{\cos x - \sin x} \\ &= \cos x + \sin x \\ &= \text{RHS} \end{aligned}$$

11 (a) LHS

$$\begin{aligned} &= \tan \theta \sec \theta - \sin \theta \\ &= \left(\frac{\sin \theta}{\cos \theta} \right) \left(\frac{1}{\cos \theta} \right) - \sin \theta \\ &= \left(\frac{\sin \theta}{\cos^2 \theta} \right) - \sin \theta \\ &= \frac{\sin \theta - (\sin \theta)(\cos^2 \theta)}{\cos^2 \theta} \\ &= \frac{\sin \theta (1 - \cos^2 \theta)}{\cos^2 \theta} \\ &= \frac{\sin \theta (\sin^2 \theta)}{\cos^2 \theta} \\ &= \frac{\sin^3 \theta}{\cos^2 \theta} \\ &= \sin^3 \theta \sec^2 \theta \\ &= \text{RHS} \end{aligned}$$

(b) LHS

$$\begin{aligned} &= \frac{1 + \cos \theta}{\sin \theta} + \frac{\sin \theta}{1 + \cos \theta} \\ &= \frac{(1 + \cos \theta)^2 + \sin^2 \theta}{\sin \theta (1 + \cos \theta)} \\ &= \frac{1 + 2 \cos \theta + \cos^2 \theta + \sin^2 \theta}{\sin \theta (1 + \cos \theta)} \\ &= \frac{1 + 2 \cos \theta + 1}{\sin \theta (1 + \cos \theta)} \\ &= \frac{2 + 2 \cos \theta}{\sin \theta (1 + \cos \theta)} \\ &= \frac{2(1 + \cos \theta)}{\sin \theta (1 + \cos \theta)} \\ &= \frac{2}{\sin \theta} \\ &= 2 \operatorname{cosec} \theta \\ &= \text{RHS} \end{aligned}$$

(c) LHS

$$\begin{aligned} &= \frac{\sec \theta + \operatorname{cosec} \theta}{\tan \theta + \cot \theta} \\ &= \frac{\frac{1}{\cos \theta} + \frac{1}{\sin \theta}}{\frac{\sin \theta}{\cos \theta} + \frac{\cos \theta}{\sin \theta}} \\ &= \frac{\frac{\sin \theta + \cos \theta}{\cos \theta \sin \theta}}{\frac{\sin^2 \theta + \cos^2 \theta}{\cos \theta \sin \theta}} \\ &= \frac{\sin \theta + \cos \theta}{1} \\ &= \sin \theta + \cos \theta \\ &= \text{RHS} \end{aligned}$$

12 (a) LHS

$$\begin{aligned} &= \cot x - \tan x \\ &= \frac{\cos x}{\sin x} - \frac{\sin x}{\cos x} \\ &= \frac{\cos^2 x - \sin^2 x}{\sin x \cos x} \\ &= \frac{\cos 2x}{\sin x \cos x} \\ &= \frac{2 \cos 2x}{2 \sin x \cos x} \\ &= \frac{2 \cos 2x}{\sin 2x} \\ &= 2 \cot 2x \\ &= \text{RHS} \end{aligned}$$

(b) LHS

$$\begin{aligned} &= \cot x - 2 \cot 2x \\ &= \frac{\cos x}{\sin x} - 2 \left(\frac{\cos 2x}{\sin 2x} \right) \\ &= \frac{\cos x}{\sin x} - 2 \left(\frac{\cos 2x}{2 \sin x \cos x} \right) \\ &= \frac{\cos x}{\sin x} - \frac{\cos 2x}{\sin x \cos x} \\ &= \frac{\cos^2 x - (\cos^2 x - \sin^2 x)}{\sin x \cos x} \\ &= \frac{\sin^2 x}{\sin x \cos x} \\ &= \frac{\sin x}{\cos x} \\ &= \tan x \\ &= \text{RHS} \end{aligned}$$

13 (a) LHS

$$\begin{aligned} &= \frac{\tan 2x}{1 + \sec 2x} \\ &= \frac{\frac{\sin 2x}{\cos 2x}}{1 + \frac{1}{\cos 2x}} \\ &= \frac{\frac{\sin 2x}{\cos 2x}}{\frac{\cos 2x + 1}{\cos 2x}} \\ &= \frac{\sin 2x}{\cos 2x + 1} \\ &= \frac{\sin 2x}{2 \cos^2 x - 1 + 1} \\ &= \frac{2 \sin x \cos x}{2 \cos^2 x} \\ &= \frac{\sin x}{\cos x} \\ &= \tan x \\ &= \text{RHS} \end{aligned}$$

(b) LHS

$$\begin{aligned} &= \operatorname{cosec} 2x + \cot 2x \\ &= \frac{1}{\sin 2x} + \frac{\cos 2x}{\sin 2x} \\ &= \frac{1 + \cos 2x}{\sin 2x} \\ &= \frac{1 + 2 \cos^2 x - 1}{2 \sin x \cos x} \\ &= \frac{2 \cos^2 x}{2 \sin x \cos x} \\ &= \frac{\cos x}{\sin x} \\ &= \cot x \\ &= \text{RHS} \end{aligned}$$

14 (a) LHS

$$\begin{aligned} &= \cot x - \cot 2x \\ &= \frac{\cos x}{\sin x} - \frac{\cos 2x}{\sin 2x} \\ &= \frac{\cos x}{\sin x} - \frac{\cos 2x}{2 \sin x \cos x} \\ &= \frac{2 \cos^2 x - \cos 2x}{2 \sin x \cos x} \\ &= \frac{2 \cos^2 x - (2 \cos^2 x - 1)}{2 \sin x \cos x} \\ &= \frac{1}{2 \sin x \cos x} \end{aligned}$$

$$\begin{aligned}
&= \frac{1}{\sin 2x} \\
&= \operatorname{cosec} 2x \\
&= \text{RHS}
\end{aligned}$$

(b) LHS

$$\begin{aligned}
&= \operatorname{cosec} x - \frac{2 \cos x \cos 2x}{\sin 2x} \\
&= \frac{1}{\sin x} - \frac{2 \cos x (\cos 2x)}{2 \sin x \cos x} \\
&= \frac{2 \cos x - 2 \cos x \cos 2x}{2 \sin x \cos x} \\
&= \frac{2 \cos x (1 - \cos 2x)}{2 \sin x \cos x} \\
&= \frac{1 - \cos 2x}{\sin x} \\
&= \frac{1 - (1 - 2 \sin^2 x)}{\sin x} \\
&= \frac{2 \sin^2 x}{\sin x} \\
&= 2 \sin x \\
&= \text{RHS}
\end{aligned}$$

15 (a) LHS

$$\begin{aligned}
&= \tan 2\theta (2 \cos \theta - \sec \theta) \\
&= \frac{\sin 2\theta}{\cos 2\theta} \left(2 \cos \theta - \frac{1}{\cos \theta} \right) \\
&= \frac{\sin 2\theta}{\cos 2\theta} \left(\frac{2 \cos^2 \theta - 1}{\cos \theta} \right) \\
&= \frac{\sin 2\theta}{\cos 2\theta} \left(\frac{\cos 2\theta}{\cos \theta} \right) \\
&= \frac{2 \sin \theta \cos \theta}{\cos \theta} \\
&= 2 \sin \theta \\
&= \text{RHS}
\end{aligned}$$

(b) LHS

$$\begin{aligned}
&= \frac{\cos (A - B)}{\sin (A + B)} \\
&= \frac{\cos A \cos B + \sin A \sin B}{\sin A \cos B + \cos A \sin B} \\
&= \frac{\frac{\cos A \cos B}{\cos A \cos B} + \frac{\sin A \sin B}{\cos A \cos B}}{\frac{\sin A \cos B}{\cos A \cos B} + \frac{\cos A \sin B}{\cos A \cos B}} \\
&= \frac{1 + \tan A \tan B}{\tan A + \tan B} \\
&= \text{RHS}
\end{aligned}$$

16 (a) LHS

$$\begin{aligned}
&= 2 \sin (\theta + 45^\circ) \cos (\theta + 45^\circ) \\
&= 2 (\sin \theta \cos 45^\circ + \cos \theta \sin 45^\circ) \\
&= (\cos \theta \cos 45^\circ - \sin \theta \sin 45^\circ) \\
&= 2 \left(\frac{\sin \theta}{\sqrt{2}} + \frac{\cos \theta}{\sqrt{2}} \right) \left(\frac{\cos \theta}{\sqrt{2}} - \frac{\sin \theta}{\sqrt{2}} \right) \\
&= 2 \left(\frac{\sin \theta + \cos \theta}{\sqrt{2}} \right) \left(\frac{\cos \theta - \sin \theta}{\sqrt{2}} \right) \\
&= \cos^2 \theta - \sin^2 \theta \\
&= \cos 2\theta \\
&= \text{RHS}
\end{aligned}$$

(b) LHS

$$\begin{aligned}
&= 2 \cos (\theta + 45^\circ) \cos (\theta - 45^\circ) \\
&= 2 (\cos \theta \cos 45^\circ - \sin \theta \sin 45^\circ) \\
&= (\cos \theta \cos 45^\circ + \sin \theta \sin 45^\circ) \\
&= 2 \left(\frac{\cos \theta}{\sqrt{2}} - \frac{\sin \theta}{\sqrt{2}} \right) \left(\frac{\cos \theta}{\sqrt{2}} + \frac{\sin \theta}{\sqrt{2}} \right) \\
&= 2 \left(\frac{\cos \theta - \sin \theta}{\sqrt{2}} \right) \left(\frac{\cos \theta + \sin \theta}{\sqrt{2}} \right) \\
&= \cos^2 \theta - \sin^2 \theta \\
&= \cos 2\theta \\
&= \text{RHS}
\end{aligned}$$

17 (a) LHS

$$\begin{aligned}
&= (\sec x - \tan x)^2 \\
&= \left(\frac{1}{\cos x} - \frac{\sin x}{\cos x} \right)^2 \\
&= \left(\frac{1 - \sin x}{\cos x} \right)^2 \\
&= \frac{(1 - \sin x)^2}{\cos^2 x} \\
&= \frac{(1 - \sin x)^2}{1 - \sin^2 x} \\
&= \frac{(1 - \sin x)^2}{(1 + \sin x)(1 - \sin x)} \\
&= \frac{1 - \sin x}{1 + \sin x} \\
&= \text{RHS}
\end{aligned}$$

(b) LHS

$$\begin{aligned}
&= \frac{\cos^2 x - \cos 2x}{\sin^2 x + \cos 2x} \\
&= \frac{\cos^2 x - (\cos^2 x - \sin^2 x)}{\sin^2 x + \cos^2 x - \sin^2 x}
\end{aligned}$$

$$\begin{aligned}
 &= \frac{\sin^2 x}{\cos^2 x} \\
 &= \tan^2 x \\
 &= \text{RHS}
 \end{aligned}$$

$$\begin{aligned}
 \mathbf{18 (a)} \quad \cos 30^\circ &= \sqrt{1 - \sin^2 30^\circ} = \sqrt{1 - h^2} \\
 \sin 40^\circ &= \sqrt{1 - \cos^2 40^\circ} = \sqrt{1 - k^2} \\
 \sin 70^\circ &= \sin (30^\circ + 40^\circ) \\
 &= \sin 30^\circ \cos 40^\circ + \cos 30^\circ \sin 40^\circ \\
 &= hk + \sqrt{1 - h^2} \sqrt{1 - k^2}
 \end{aligned}$$

$$\mathbf{(b)} \quad \cos 80^\circ = 2 \cos^2 40^\circ - 1 = 2k^2 - 1$$

$$\begin{aligned}
 \mathbf{(c)} \quad \cos 40^\circ &= 2 \cos^2 20^\circ - 1 \\
 k &= 2 \cos^2 20^\circ - 1 \\
 \frac{k+1}{2} &= \cos^2 20^\circ \\
 \cos 20^\circ &= \sqrt{\frac{k+1}{2}}
 \end{aligned}$$

19

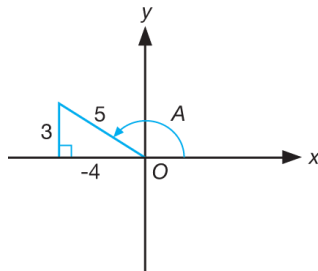

$$\tan A = -\frac{3}{4}$$

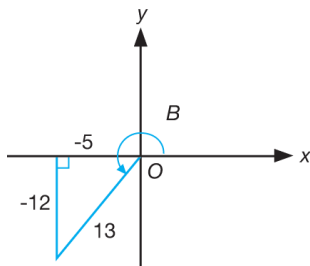

$$\tan B = \frac{12}{5}$$

$$\begin{aligned}
 \tan (A+B) &= \frac{\tan A + \tan B}{1 - \tan A \tan B} \\
 &= \frac{-\frac{3}{4} + \frac{12}{5}}{1 - \left(-\frac{3}{4}\right)\left(\frac{12}{5}\right)}
 \end{aligned}$$

$$\begin{aligned}
 &= \frac{33}{56} \\
 &= \frac{20}{14} \\
 &= \frac{33}{56}
 \end{aligned}$$

$$\mathbf{20 (a)} \quad 8 \tan \theta = 3 \cos \theta$$

$$\frac{8 \sin \theta}{\cos \theta} = 3 \cos \theta$$

$$8 \sin \theta = 3 \cos^2 \theta$$

$$8 \sin \theta = 3(1 - \sin^2 \theta)$$

$$8 \sin \theta = 3 - 3 \sin^2 \theta$$

$$3 \sin^2 \theta + 8 \sin \theta - 3 = 0$$

$$(3 \sin \theta - 1)(\sin \theta + 3) = 0$$

$$\sin \theta = \frac{1}{3} \text{ or } \sin \theta = -3$$

$\sin \theta = -3$ is not accepted because the minimum value of $\sin \theta$ is -1 .

$$\text{When } \sin \theta = \frac{1}{3},$$

$$\text{Basic } \angle = 19.47^\circ$$

$$\theta = 19.47^\circ, 160.53^\circ$$

$$\mathbf{(b)} \quad 2 \tan \theta + 5 \sin \theta = 0$$

$$\frac{2 \sin \theta}{\cos \theta} + 5 \sin \theta = 0$$

$$2 \sin \theta + 5 \sin \theta \cos \theta = 0$$

$$\sin \theta (2 + 5 \cos \theta) = 0$$

$$\sin \theta = 0 \text{ or } \cos \theta = -\frac{2}{5}$$

$$\text{When } \sin \theta = 0,$$

$$\theta = 0^\circ, 180^\circ, 360^\circ$$

$$\text{When } \cos \theta = -\frac{2}{5},$$

$$\text{Basic } \angle = 66.42^\circ$$

$$\theta = 113.58^\circ, 246.42^\circ$$

$$\mathbf{(c)} \quad 3(\cos \theta - \sin \theta) = \sin \theta$$

$$3 \cos \theta - 3 \sin \theta = \sin \theta$$

$$3 \cos \theta = 4 \sin \theta$$

$$\frac{\sin \theta}{\cos \theta} = \frac{3}{4}$$

$$\tan \theta = 0.75$$

$$\text{Basic } \angle = 36.87^\circ$$

$$\theta = 36.87^\circ, 216.87^\circ$$

21 (a) $2 \sin \theta = \operatorname{cosec} \theta$

$$2 \sin \theta = \frac{1}{\sin \theta}$$

$$\sin^2 \theta = \frac{1}{2}$$

$$\sin \theta = \pm \frac{1}{\sqrt{2}}$$

$$\theta = 45^\circ, 135^\circ, 225^\circ, 315^\circ$$

(b) $\tan \theta = 3 \cot \theta$

$$\frac{\sin \theta}{\cos \theta} = \frac{3 \cos \theta}{\sin \theta}$$

$$\sin^2 \theta = 3 \cos^2 \theta$$

$$\frac{\sin^2 \theta}{\cos^2 \theta} = 3$$

$$\tan^2 \theta = 3$$

$$\tan \theta = \pm \sqrt{3}$$

$$\theta = 60^\circ, 120^\circ, 240^\circ, 300^\circ$$

(c) $4 \cos \theta = 3 \sec \theta$

$$4 \cos \theta = \frac{3}{\cos \theta}$$

$$\cos^2 \theta = \frac{3}{4}$$

$$\cos \theta = \pm \frac{\sqrt{3}}{2}$$

Basic $\angle = 30^\circ$

$$\theta = 30^\circ, 150^\circ, 210^\circ, 330^\circ$$

22 (a) $2 \sec \theta - \cos \theta = 1$

$$\frac{2}{\cos \theta} - \cos \theta - 1 = 0$$

$$2 - \cos \theta^2 - \cos \theta = 0$$

$$\cos^2 \theta + \cos \theta - 2 = 0$$

$$(\cos \theta - 1)(\cos \theta + 2) = 0$$

$$\cos \theta = 1 \text{ or } \cos \theta = -2$$

$\cos \theta = -2$ does not have solution

because the minimum value of $\cos \theta$ is -1 .

When $\cos \theta = 1$,

$$\theta = 0^\circ, 360^\circ$$

(b) $\cos^2 \theta + 7 \sin^2 \theta + \sin \theta = 2$

$$1 - \sin^2 \theta + 7 \sin^2 \theta + \sin \theta - 2 = 0$$

$$6 \sin^2 \theta + \sin \theta - 1 = 0$$

$$(3 \sin \theta - 1)(2 \sin \theta + 1) = 0$$

$$\sin \theta = \frac{1}{3} \text{ or } \sin \theta = -\frac{1}{2}$$

When $\sin \theta = \frac{1}{3}$,

Basic $\angle = 19.47^\circ$

$$\theta = 19.47^\circ, 160.53^\circ$$

When $\sin \theta = -\frac{1}{2}$,

$$\theta = 210^\circ, 330^\circ$$

(c) $\sin \theta (\sin \theta + 1) + \cos \theta (\cos \theta - 2) = 1$

$$\sin^2 \theta + \sin \theta + \cos^2 \theta - 2 \cos \theta - 1 = 0$$

$$1 + \sin \theta - 2 \cos \theta - 1 = 0$$

$$\sin \theta = 2 \cos \theta$$

$$\frac{\sin \theta}{\cos \theta} = 2$$

$$\tan \theta = 2$$

Basic $\angle = 63.43^\circ, 243.43^\circ$

23 (a) $4 \tan 2x = \cot x$

$$4 \left(\frac{2 \tan x}{1 - \tan^2 x} \right) = \frac{1}{\tan x}$$

$$8 \tan^2 x = 1 - \tan^2 x$$

$$9 \tan^2 x = 1$$

$$\tan^2 x = \frac{1}{9}$$

$$\tan x = \pm \frac{1}{3}$$

Basic $\angle = 18.43^\circ$

$$x = 18.43^\circ, 161.57^\circ$$

$$198.43^\circ, 341.57^\circ$$

(b) $2 \tan \theta = 3 \tan (45^\circ - \theta)$

$$2 \tan \theta = \frac{3 \tan 45^\circ - 3 \tan \theta}{1 + \tan 45^\circ \tan \theta}$$

$$2 \tan \theta = \frac{3 - 3 \tan \theta}{1 + \tan \theta}$$

$$2 \tan \theta + 2 \tan^2 \theta = 3 - 3 \tan \theta$$

$$2 \tan^2 \theta + 5 \tan \theta - 3 = 0$$

$$(2 \tan \theta - 1)(\tan \theta + 3) = 0$$

$$\tan \theta = \frac{1}{2} \text{ or } \tan \theta = -3$$

When $\tan \theta = \frac{1}{2}$,

Basic $\angle = 26.57^\circ$

$$\theta = 26.57^\circ, 206.57^\circ$$

When $\tan \theta = -3$,

$$\text{Basic } \angle = 71.57^\circ$$

$$\theta = 108.43^\circ, 288.43^\circ$$

$$24 \quad 5 \sin x \cos x - \sin x = 0$$

$$\sin x (5 \cos x - 1) = 0$$

$$\sin x = 0 \text{ or } \cos x = \frac{1}{5}$$

When $\sin x = 0$,

$$x = 0^\circ, 180^\circ, 360^\circ$$

When $\cos x = \frac{1}{5}$,

$$\text{Basic } \angle = 78.46^\circ$$

$$x = 78.46^\circ, 281.54^\circ$$

$$25 \text{ (a)} \quad 4 \cos 2x + 2 \sin x = 3$$

$$4(1 - 2 \sin^2 x) + 2 \sin x - 3 = 0$$

$$4 - 8 \sin^2 x + 2 \sin x - 3 = 0$$

$$8 \sin^2 x - 2 \sin x - 1 = 0$$

$$(2 \sin x - 1)(4 \sin x + 1) = 0$$

$$\sin x = \frac{1}{2} \text{ or } \sin x = -\frac{1}{4}$$

When $\sin x = \frac{1}{2}$,

$$x = 30^\circ, 150^\circ$$

When $\sin x = -\frac{1}{4}$,

$$\text{Basic } \angle = 14.48^\circ$$

$$x = 194.48^\circ, 345.52^\circ$$

$$\text{(b)} \quad 3 \cos 2x - 10 \cos x + 7 = 0$$

$$3(2 \cos^2 x - 1) - 10 \cos x + 7 = 0$$

$$6 \cos^2 x - 3 - 10 \cos x + 7 = 0$$

$$6 \cos^2 x - 10 \cos x + 4 = 0$$

$$3 \cos^2 x - 5 \cos x + 2 = 0$$

$$(\cos x - 1)(3 \cos x - 2) = 0$$

$$\cos x = 1 \text{ or } \cos x = \frac{2}{3}$$

When $\cos x = 1$, $x = 0^\circ, 360^\circ$

When $\cos x = \frac{2}{3}$,

$$\text{Basic } \angle = 48.19^\circ$$

$$x = 48.19^\circ, 311.81^\circ$$

$$26 \text{ (a)} \quad \sin \theta = \cos(\theta + 30^\circ)$$

$$\sin \theta = \cos \theta \cos 30^\circ - \sin \theta \sin 30^\circ$$

$$\sin \theta = \frac{\sqrt{3}}{2} \cos \theta - \frac{1}{2} \sin \theta$$

$$2 \sin \theta = \sqrt{3} \cos \theta - \sin \theta$$

$$2 \sin \theta = \sqrt{3} \cos \theta - \sin \theta$$

$$\frac{\sin \theta}{\cos \theta} = \frac{\sqrt{3}}{3}$$

$$\tan \theta = 0.5774$$

$$\text{Basic } \angle = 30^\circ$$

$$\theta = 30^\circ, 210^\circ$$

$$\text{(b)} \quad \cos \theta = 4 \cos(\theta - 60^\circ)$$

$$\cos \theta = 4(\cos \theta \cos 60^\circ + \sin \theta \sin 60^\circ)$$

$$\cos \theta = 4\left(\frac{\cos \theta}{2} + \frac{\sqrt{3}}{2} \sin \theta\right)$$

$$\cos \theta = 2 \cos \theta + 2\sqrt{3} \sin \theta$$

$$-\cos \theta = 2\sqrt{3} \sin \theta$$

$$-\frac{1}{2\sqrt{3}} = \frac{\sin \theta}{\cos \theta}$$

$$\tan \theta = -0.2886$$

$$\text{Basic } \angle = 16.10^\circ$$

$$\theta = 163.90^\circ, 343.90^\circ$$

$$27 \text{ (a)} \quad 8 \sin x + 3 \sec x = 0$$

$$8 \sin x + \frac{3}{\cos x} = 0$$

$$8 \sin x \cos x + 3 = 0$$

$$4(2 \sin x \cos x) + 3 = 0$$

$$4 \sin 2x = -3$$

$$\sin 2x = -\frac{3}{4}$$

$$\text{Basic } \angle = 48.59^\circ$$

$$2x = 228.59^\circ, 311.41^\circ$$

$$x = 114.30, 155.70^\circ$$

$$\text{(b)} \quad 3 \cos^2 x - 3 \sin^2 x - 8 \sin x \cos x = 0$$

$$(\cos x - 3 \sin x)(3 \cos x + \sin x) = 0$$

$$\cos x - 3 \sin x = 0 \text{ or}$$

$$3 \cos x + \sin x = 0$$

When

$$\cos x - 3 \sin x = 0,$$

$$\cos x = 3 \sin x$$

$$\frac{\sin x}{\cos x} = \frac{1}{3}$$

$$\tan x = \frac{1}{3}$$

$$\text{Basic } \angle = 18.43^\circ$$

$$x = 18.43^\circ$$

When

$$3 \cos x + \sin x = 0,$$

$$3 \cos x = -\sin x$$

$$\frac{\sin x}{\cos x} = -3$$

$$\tan x = -3$$

$$\text{Basic } \angle = 71.57^\circ$$

28 (a) LHS

$$= \cot x \sin 2x$$

$$= \left(\frac{\cos x}{\sin x} \right) (2 \sin x \cos x)$$

$$= 2 \cos^2 x$$

$$= \cos 2x + 1$$

$$= \text{RHS}$$

$$\cos 2x = 2 \cos^2 x - 1$$

$$2 \cos^2 x = \cos 2x + 1$$

(b) $\cot x \sin 2x = \frac{2}{3}$

$$\cos 2x + 1 = \frac{2}{3}$$

$$\cos 2x = -\frac{1}{3}$$

$$\text{Basic } \angle = 70.53^\circ$$

$$2x = 109.47^\circ, 250.53^\circ,$$

$$469.47^\circ, 610.53^\circ$$

$$x = 54.74^\circ, 125.27^\circ,$$

$$234.74^\circ, 305.27^\circ$$

29 (a) (i) LHS

$$= 2 \sin (x + 45^\circ) \sin (x - 45^\circ)$$

$$= 2(\sin x \cos 45^\circ + \cos x \sin 45^\circ)$$

$$(\sin x \cos 45^\circ - \cos x \sin 45^\circ)$$

$$= 2 \left(\frac{\sin x}{\sqrt{2}} + \frac{\cos x}{\sqrt{2}} \right) \left(\frac{\sin x}{\sqrt{2}} - \frac{\cos x}{\sqrt{2}} \right)$$

$$= (\sin x + \cos x)(\sin x - \cos x)$$

$$= \sin^2 x - \cos^2 x$$

$$= -\cos 2x$$

$$= \text{RHS}$$

(ii) $2 \sin (x + 45^\circ) \sin (x - 45^\circ) = \frac{1}{2}$

$$-\cos 2x = \frac{1}{2}$$

$$\cos 2x = -\frac{1}{2}$$

$$\text{Basic } \angle = 60^\circ$$

$$2x = 120^\circ, 240^\circ, 480^\circ, 600^\circ$$

$$x = 60^\circ, 120^\circ, 240^\circ, 300^\circ$$

(b)

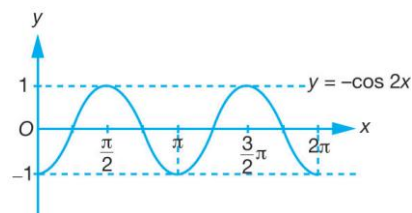

30 (a)

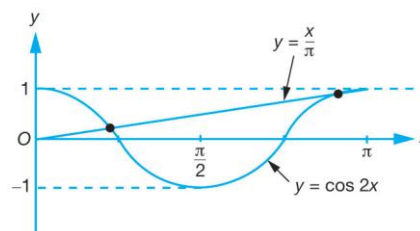

(b) $1 - 2 \sin^2 x - \frac{x}{\pi} = 0$

$$\cos 2x = \frac{x}{\pi}$$

Sketch the straight line $y = \frac{x}{\pi}$

Number of solutions

= Number of points of intersection

= 2

31 (a) LHS

$$= \sec^2 x - \tan^2 x - 2 \cos^2 x$$

$$= 1 + \tan^2 x - \tan^2 x - 2 \cos^2 x$$

$$= 1 - 2 \cos^2 x$$

$$= -(2 \cos^2 x - 1)$$

$$= -\cos 2x$$

$$= \text{RHS}$$

(b) $2(\sec^2 x - \tan^2 x - 2 \cos^2 x) = \frac{x}{\pi} - 1$

$$-2 \cos 2x = \frac{x}{\pi} - 1$$

$$-\cos 2x = \frac{x}{2\pi} - \frac{1}{2}$$

Sketch the straight line $y = \frac{x}{2\pi} - \frac{1}{2}$

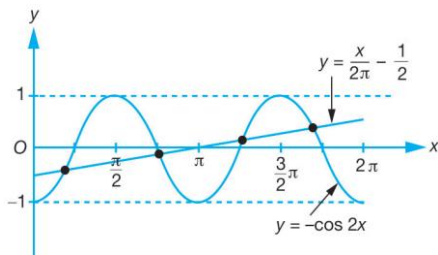

Number of solutions
= Number of points of intersection
= 4

32 (a) LHS

$$\begin{aligned} &= \frac{2 \cot x}{2 - \operatorname{cosec}^2 x} \\ &= \frac{2 \cos x}{2 - \frac{1}{\sin^2 x}} \\ &= \frac{\sin x}{2 - \frac{1}{\sin^2 x}} \\ &= \frac{2 \cos x}{2 \sin^2 x - 1} \\ &= \frac{\sin x}{2 \sin^2 x - 1} \\ &= \frac{2 \cos x}{\sin x} \times \frac{\sin^2 x}{2 \sin^2 x - 1} \\ &= \frac{2 \sin x \cos x}{2 \sin^2 x - 1} \\ &= \frac{\sin 2x}{-(1 - 2 \sin^2 x)} \\ &= \frac{\sin 2x}{-\cos 2x} \\ &= -\tan 2x \\ &= \text{RHS} \end{aligned}$$

(b) (i)

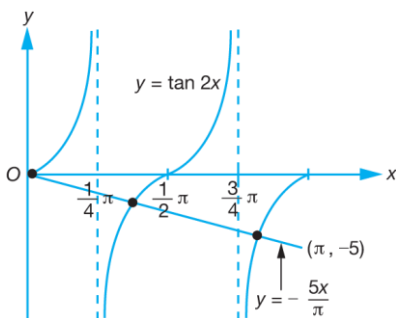

(ii) $\frac{2 \cot x}{2 - \operatorname{cosec}^2 x} - \frac{5x}{\pi} = 0$
 $-\tan 2x = \frac{5x}{\pi}$

$$\tan 2x = -\frac{5x}{\pi}$$

Sketch the straight line $y = -\frac{5x}{\pi}$.

Number of solutions
= Number of points of intersection
= 3

33 (a) LHS

$$\begin{aligned} &= \tan 2x (2 \cos x - \sec x) \\ &= \frac{\sin 2x}{\cos 2x} \left(2 \cos x - \frac{1}{\cos x} \right) \\ &= \frac{2 \sin x \cos x}{\cos 2x} \left(\frac{2 \cos^2 x - 1}{\cos x} \right) \end{aligned}$$

$$= \frac{2 \sin x}{\cos 2x} (\cos 2x)$$

$$= 2 \sin x$$

$$= \text{RHS}$$

(b) $\pi \tan 2x (2 \cos x - \sec x) + x = 0$

$$\tan 2x (2 \cos x - \sec x) = -\frac{x}{\pi}$$

$$2 \sin x = -\frac{x}{\pi}$$

Sketch the straight line $y = -\frac{x}{\pi}$

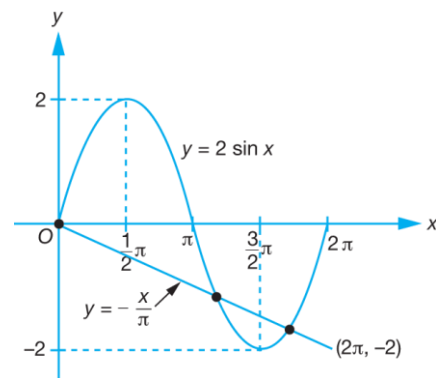

Number of solutions
= Number of points of intersection
= 3

34 (a) LHS

$$= \frac{\sin 2x}{2 \cos^2 x + \cot^2 x - \operatorname{cosec}^2 x}$$

$$= \frac{\sin 2x}{2 \cos^2 x - 1}$$

$$= \frac{\sin 2x}{\cos 2x}$$

$$= \tan 2x$$

$$= \text{RHS}$$

(b)

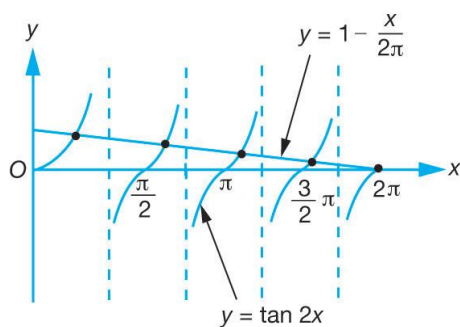

$$(c) \frac{\sin 2x}{2 \cos^2 x + \cot^2 x - \operatorname{cosec}^2 x} + \frac{x}{2\pi} = 1$$

$$\tan 2x = 1 - \frac{x}{2\pi}$$

Sketch the straight line $y = 1 - \frac{x}{2\pi}$.

Number of solutions
= Number of points of intersection
= 5

35 (a) LHS

$$\begin{aligned} &= 2 \cot x \sin^2 x \\ &= 2 \left(\frac{\cos x}{\sin x} \right) (\sin^2 x) \\ &= 2 \sin x \cos x \\ &= \sin 2x \\ &= \text{RHS} \end{aligned}$$

$$(b) \quad 4 \cot x \sin^2 x = \sqrt{3}$$

$$2(2 \cot x \sin^2 x) = \sqrt{3}$$

$$2(\sin 2x) = \sqrt{3}$$

$$\sin 2x = \frac{\sqrt{3}}{2}$$

$$\text{Basic } \angle = 60^\circ$$

$$2x = 60^\circ, 120^\circ, 420^\circ, 480^\circ$$

$$x = 30^\circ, 60^\circ, 210^\circ, 240^\circ$$

$$x = \frac{1}{6}\pi, \frac{1}{3}\pi, \frac{7}{6}\pi, \frac{4}{3}\pi \text{ rad}$$

(c) (i)

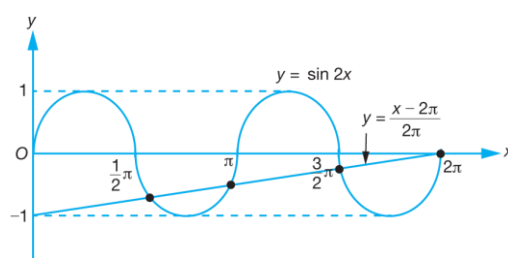

Sketch the straight line $y = \frac{x-2\pi}{2\pi}$

Number of solutions
= Number of points of intersection
= 4

$$36 \quad e = 0.014 \cos(2\pi ft)$$

$$2\pi ft = 2\pi$$

$$ft = 1$$

$$t = \frac{1}{f}$$

$$\text{Period} = \frac{1}{f} = \frac{1}{950\,000} = 1.053 \times 10^{-6} \text{ s}$$