

Tingkatan 5 Bab 2
Pembezaan
Penyelesaian Lengkap

Praktis Formatif 2.1a

$$\begin{aligned} 1 \text{ (a)} \quad & \lim_{n \rightarrow 0} \left(\frac{n^2 + n}{n} \right) \\ &= \lim_{n \rightarrow 0} \left(\frac{n(n+1)}{n} \right) \\ &= \lim_{n \rightarrow 0} (n+1) \\ &= 0+1 \\ &= 1 \end{aligned}$$

$$\begin{aligned} \text{(b)} \quad & \lim_{n \rightarrow 7} \left(\frac{n^2 - 49}{n - 7} \right) \\ &= \lim_{n \rightarrow 7} \left(\frac{(n+7)(n-7)}{n-7} \right) \\ &= \lim_{n \rightarrow 7} (n+7) \\ &= 7+7 \\ &= 14 \end{aligned}$$

$$\begin{aligned} \text{(c)} \quad & \lim_{n \rightarrow 1} \left(\frac{n^2 + n - 2}{n - 1} \right) \\ &= \lim_{n \rightarrow 1} \left(\frac{(n+2)(n-1)}{n-1} \right) \\ &= \lim_{n \rightarrow 1} (n+2) \\ &= 1+2 \\ &= 3 \end{aligned}$$

$$\begin{aligned} \text{(d)} \quad & \lim_{n \rightarrow 2} \left(\frac{n^2 - n - 2}{n^2 - 5n + 6} \right) \\ &= \lim_{n \rightarrow 2} \left(\frac{(n-2)(n+1)}{(n-3)(n-2)} \right) \\ &= \lim_{n \rightarrow 2} \left(\frac{n+1}{n-3} \right) \\ &= \frac{2+1}{2-3} \\ &= -3 \end{aligned}$$

Praktis Formatif 2.1b

$$\begin{aligned} 1 \text{ (a)} \quad & y = x^2 - 2 \quad \dots (1) \\ & y + \delta y = (x + \delta x)^2 - 2 \\ & y + \delta y = x^2 + 2x\delta x + (\delta x)^2 - 2 \quad \dots (2) \end{aligned}$$

$$(2) - (1) :$$

$$\delta y = 2x\delta x + (\delta x)^2$$

$$\frac{\delta y}{\delta x} = 2x + \delta x$$

$$\frac{dy}{dx} = \lim_{\delta x \rightarrow 0} \left(\frac{\delta y}{\delta x} \right)$$

$$\frac{dy}{dx} = \lim_{\delta x \rightarrow 0} (2x + \delta x)$$

$$\frac{dy}{dx} = 2x + 0$$

$$\frac{dy}{dx} = 2x$$

$$\text{(b)} \quad y = x^2 + x - 6 \quad \dots (1)$$

$$\begin{aligned} & y + \delta y = (x + \delta x)^2 + x + \delta x - 6 \\ & y + \delta y = x^2 + 2x\delta x + (\delta x)^2 + x + \delta x - 6 \quad \dots (2) \end{aligned}$$

$$(2) - (1) : \delta y = 2x\delta x + (\delta x)^2 + \delta x$$

$$\frac{\delta y}{\delta x} = 2x + \delta x + 1$$

$$\frac{dy}{dx} = \lim_{\delta x \rightarrow 0} \left(\frac{\delta y}{\delta x} \right)$$

$$\frac{dy}{dx} = \lim_{\delta x \rightarrow 0} (2x + \delta x + 1)$$

$$\frac{dy}{dx} = 2x + 0 + 1$$

$$\frac{dy}{dx} = 2x + 1$$

$$2 \text{ (a)} \quad y = \frac{3}{x} \quad \dots (1)$$

$$y + \delta y = \frac{3}{x + \delta x} \quad \dots (2)$$

$$(2) - (1) :$$

$$\delta y = \frac{3}{x + \delta x} - \frac{3}{x}$$

$$\delta y = \frac{3x - 3(x + \delta x)}{(x + \delta x)^2}$$

$$\delta y = \frac{-3\delta x}{(x + \delta x)^2}$$

$$\frac{\delta y}{\delta x} = \frac{-3}{(x + \delta x)^2}$$

Praktis Formatif 2.2a

$$\frac{dy}{dx} = \text{had}_{\delta x \rightarrow 0} \left(\frac{\delta y}{\delta x} \right)$$

$$\frac{dy}{dx} = \text{had}_{\delta x \rightarrow 0} \frac{-3}{(x + \delta x)^2}$$

$$\frac{dy}{dx} = \frac{-3}{(x+0)^2}$$

$$\frac{dy}{dx} = \frac{-3}{x^2}$$

(b) $y = \frac{5}{x^2} \dots (1)$

$$y + \delta y = \frac{5}{(x + \delta x)^2} \dots (2)$$

(2) - (1) :

$$\delta y = \frac{5}{(x + \delta x)^2} - \frac{5}{x^2}$$

$$\delta y = \frac{5x^2 - 5[(x + \delta x)^2]}{x^2(x + \delta x)^2}$$

$$\delta y = \frac{5x^2 - 5[x^2 + 2x\delta x + (\delta x)^2]}{x^2(x + \delta x)^2}$$

$$\delta y = \frac{5x^2 - 5x^2 - 10x\delta x - 5(\delta x)^2}{x^2(x + \delta x)^2}$$

$$\delta y = \frac{-10x\delta x - 5(\delta x)^2}{x^2(x + \delta x)^2}$$

$$\frac{\delta y}{\delta x} = \frac{-10x - 5\delta x}{x^2(x + \delta x)^2}$$

$$\frac{dy}{dx} = \text{had}_{\delta x \rightarrow 0} \left(\frac{\delta y}{\delta x} \right)$$

$$\frac{dy}{dx} = \text{had}_{\delta x \rightarrow 0} \left(\frac{-10x - 5\delta x}{x^2(x + \delta x)^2} \right)$$

$$\frac{dy}{dx} = \frac{-10x - 5(0)}{x^2(x+0)^2}$$

$$\frac{dy}{dx} = \frac{-10x}{x^2(x)^2}$$

$$\frac{dy}{dx} = \frac{-10}{x^3}$$

1 (a) $y = 24$

$$\frac{dy}{dx} = 0$$

(b) $y = 6x$

$$\frac{dy}{dx} = 6$$

(c) $y = x^8$

$$\frac{dy}{dx} = 8x^7$$

(d) $y = 5x^4$

$$\frac{dy}{dx} = 20x^3$$

(e) $y = \frac{4}{x}$

$$\frac{dy}{dx} = -\frac{4}{x^2}$$

(f) $y = -\frac{4}{x^3}$

$$\frac{dy}{dx} = \frac{12}{x^4}$$

(g) $y = \frac{x^5}{15}$

$$\frac{dy}{dx} = \frac{1}{15}(5x^4) = \frac{x^4}{3}$$

(h) $y = -\frac{3}{4x^8} = -\frac{3}{4}(x^{-8})$

$$\frac{dy}{dx} = -\frac{3}{4}(-8x^{-9}) = 6x^{-9} = \frac{6}{x^9}$$

2 (a) $\frac{d}{dx}(x^6 - 3x^3 + 5) = 6x^5 - 9x^2$

(b) $\frac{d}{dx} \left(\frac{1}{2}t^4 + 3t^2 + 6 \right) = 2t^3 + 6t$

(c) $\frac{d}{dj}(5j^3 - 4j^2 - 3j) = 15j^2 - 8j - 3$

3 (a) $f(x) = 3x^2 + \frac{3}{x} + \frac{3}{x^2}$

$$f'(x) = 6x - \frac{3}{x^2} - \frac{6}{x^3}$$

$$(b) f(x) = 2x + \frac{2}{x} - \frac{2}{x^3}$$

$$f'(x) = 2 - \frac{2}{x^2} + \frac{6}{x^4}$$

$$(c) f(x) = \frac{1}{x} + \frac{1}{x^2} + \frac{1}{x^3}$$

$$f'(x) = -\frac{1}{x^2} - \frac{2}{x^3} - \frac{3}{x^4}$$

$$4 (a) s = (t-1)(2t+5)$$

$$s = 2t^2 + 3t - 5$$

$$\frac{ds}{dt} = 4t + 3$$

$$(b) s = (2t-5)^2 = 4t^2 - 20t + 25$$

$$\frac{ds}{dt} = 8t - 20$$

$$(c) s = 3t^2(t-2)^2$$

$$s = 3t^2(t^2 - 4t + 4)$$

$$s = 3t^4 - 12t^3 + 12t^2$$

$$\frac{ds}{dt} = 12t^3 - 36t^2 + 24t$$

$$(d) s = \left(t - \frac{2}{t}\right)^2 = t^2 - 4 + \frac{4}{t^2}$$

$$\frac{ds}{dt} = 2t - \frac{8}{t^3}$$

$$5 (a) v = \frac{2t^2 - 9}{t} = 2t - \frac{9}{t}$$

$$\frac{dv}{dt} = 2 + \frac{9}{t^2}$$

$$(b) v = \frac{t^2 + 6t - 12}{t^2} = 1 + \frac{6}{t} - \frac{12}{t^2}$$

$$\frac{dv}{dt} = -\frac{6}{t^2} + \frac{24}{t^3}$$

$$(c) v = \frac{(t+1)(2-3t)}{t^2} = \frac{2-t-3t^2}{t^2}$$

$$v = \frac{2}{t^2} - \frac{1}{t} - 3$$

$$\frac{dv}{dt} = -\frac{4}{t^3} + \frac{1}{t^2}$$

Praktis Formatif 2.2b

$$1 (a) y = 2x^3(2-x^5) = 4x^3 - 2x^8$$

$$\frac{dy}{dx} = 12x^2 - 16x^7$$

$$(b) y = (6+x^2)(5-3x)$$

$$= 30 - 18x + 5x^2 - 3x^3$$

$$\frac{dy}{dx} = -9x^2 + 10x - 18$$

$$(c) y = (5x^2 - 4)(3 - x)$$

$$= 15x^2 - 5x^3 - 12 + 4x$$

$$\frac{dy}{dx} = -15x^2 + 30x + 4$$

$$(d) y = (x^4 + 1)(x^3 - 2x)$$

$$= x^7 - 2x^5 + x^3 - 2x$$

$$\frac{dy}{dx} = 7x^6 - 10x^4 + 3x^2 - 2$$

$$(e) y = (2x-1)(x^2 + 3x - 2)$$

$$\frac{dy}{dx} = (2x-1)(2x+3) + (x^2 + 3x - 2)(2)$$

$$= 4x^2 + 4x - 3 + 2x^2 + 6x - 4$$

$$= 6x^2 + 10x - 7$$

$$(f) y = (2x^2 + 1)(3x^2 + x - 4)$$

$$\frac{dy}{dx} = (2x^2 + 1)(6x + 1) + (3x^2 + x - 4)(4x)$$

$$= 12x^3 + 2x^2 + 6x + 1 +$$

$$12x^3 + 4x^2 - 16x$$

$$= 24x^3 + 6x^2 - 10x + 1$$

$$(g) y = \left(\frac{1}{x} + 1\right)\left(\frac{2}{x^2} - 3\right)$$

$$y = \frac{2}{x^3} - \frac{3}{x} + \frac{2}{x^2} - 3$$

$$\frac{dy}{dx} = -\frac{6}{x^4} + \frac{3}{x^2} - \frac{4}{x^3}$$

$$(h) y = (2x^2 + x^3)\left(x - \frac{2}{x}\right)$$

$$= 2x^3 - 4x + x^4 - 2x^2$$

$$\frac{dy}{dx} = 6x^2 - 4 + 4x^3 - 4x$$

$$2 \text{ (a) } f(x) = x(x^2 + 4x - 3)$$

$$= x^3 + 4x^2 - 3x$$

$$f'(x) = 3x^2 + 8x - 3$$

$$(b) f'(x) = 0$$

$$3x^2 + 8x - 3 = 0$$

$$x = \frac{1}{3} \text{ atau } -3$$

$$3 \text{ (a) } y = \frac{5x}{x+3}$$

$$\frac{dy}{dx} = \frac{5(x+3) - 5x}{(x+3)^2}$$

$$= \frac{5x + 15 - 5x}{(x+3)^2}$$

$$= \frac{15}{(x+3)^2}$$

$$(b) y = \frac{6x^2}{x-5}$$

$$\frac{dy}{dx} = \frac{(x-5)(12x) - 6x^2}{(x-5)^2}$$

$$= \frac{12x^2 - 60x - 6x^2}{(x-5)^2}$$

$$= \frac{6x^2 - 60x}{(x-5)^2}$$

$$(c) y = \frac{2x-5}{2x+3}$$

$$\frac{dy}{dx} = \frac{(2x+3)(2) - (2x-5)(2)}{(2x+3)^2}$$

$$= \frac{4x+6-4x+10}{(2x+3)^2}$$

$$= \frac{16}{(2x+3)^2}$$

$$(d) y = \frac{x^2-5}{x+3}$$

$$\frac{dy}{dx} = \frac{(x+3)(2x) - (x^2-5)}{(x+3)^2}$$

$$= \frac{2x^2+6x-x^2+5}{(x+3)^2}$$

$$= \frac{x^2+6x+5}{(x+3)^2}$$

$$(e) y = \frac{4x^2}{7-x^2}$$

$$\frac{dy}{dx} = \frac{(7-x^2)(8x) - 4x^2(-2x)}{(7-x^2)^2}$$

$$= \frac{56x - 8x^3 + 8x^3}{(7-x^2)^2}$$

$$= \frac{56x}{(7-x^2)^2}$$

$$(f) y = \frac{x^2}{x^2-5}$$

$$\frac{dy}{dx} = \frac{(x^2-5)(2x) - (x^2)(2x)}{(x^2-5)^2}$$

$$= \frac{2x^3 - 10x - 2x^3}{(x^2-5)^2}$$

$$= \frac{-10x}{(x^2-5)^2}$$

$$(g) y = \frac{3x^4}{9-x^2}$$

$$\frac{dy}{dx} = \frac{(9-x^2)(12x^3) - 3x^4(-2x)}{(9-x^2)^2}$$

$$= \frac{108x^3 - 12x^5 + 6x^5}{(9-x^2)^2}$$

$$= \frac{108x^3 - 6x^5}{(9-x^2)^2}$$

$$(h) y = \frac{x^2-2x}{x^2+3x}$$

$$\frac{dy}{dx} = \frac{(x^2+3x)(2x-2) - (x^2-2x)(2x+3)}{(x^2+3x)^2}$$

$$= \frac{2x^3 - 2x^2 + 6x^2 - 6x - [2x^3 + 3x^2 - 4x^2 - 6x]}{(x^2+3x)^2} =$$

$$= \frac{2x^3 + 4x^2 - 6x - [2x^3 - x^2 - 6x]}{(x^2+3x)^2}$$

$$= \frac{5x^2}{(x^2+3x)^2}$$

$$4 \text{ (a) } f(x) = \frac{2-x}{x^2+5}$$

$$f'(x) = \frac{(x^2+5)(-1) - (2-x)(2x)}{(x^2+5)^2}$$

$$= \frac{-x^2-5-4x+2x^2}{(x^2+5)^2}$$

$$= \frac{x^2-4x-5}{(x^2+5)^2}$$

$$(b) f'(x) = 0$$

$$x^2 - 4x - 5 = 0$$

$$x = 5 \text{ atau } -1$$

$$5 \text{ (a) } y = (4x+7)^5$$

$$\frac{dy}{dx} = 5(4x+7)^4(4) = 20(4x+7)^4$$

$$(b) y = (6-x^2)^4$$

$$\frac{dy}{dx} = 4(6-x^2)^3(-2x) = -8x(6-x^2)^3$$

$$(c) y = \left(\frac{1}{3}x^3 - 9\right)^6$$

$$\frac{dy}{dx} = 6\left(\frac{x^3}{3} - 9\right)^5 \left(x^2\right) = 6x^2\left(\frac{x^3}{3} - 9\right)^5$$

$$(d) y = (x^2 + 5x - 3)^3$$

$$\frac{dy}{dx} = 3(x^2 + 5x - 3)^2(2x + 5)$$

$$6 \text{ (a) } s = \frac{2}{5t+1} = 2(5t+1)^{-1}$$

$$\frac{ds}{dt} = -2(5t+1)^{-2}(5)$$

$$= -\frac{10}{(5t+1)^2}$$

$$(b) s = \frac{3}{t^2+4} = 3(t^2+4)^{-1}$$

$$\frac{ds}{dt} = -3(t^2+4)^{-2}(2t)$$

$$= \frac{-6t}{(t^2+4)^2}$$

$$(c) s = \frac{5}{(t^2-2)^3} = 5(t^2-2)^{-3}$$

$$\frac{ds}{dt} = -15(t^2-2)^{-4}(2t) = \frac{-30t}{(t^2-2)^4}$$

$$(d) s = \frac{1}{(2t^2-t+2)^3} = (2t^2-t+2)^{-3}$$

$$\frac{ds}{dt} = -3(2t^2-t+2)^{-4}(4t-1)$$

$$\frac{ds}{dt} = \frac{-12t+3}{(2t^2-t+2)^4}$$

$$7 \text{ (a) } y = x^2(x+1)^4$$

$$\frac{dy}{dt} = x^2(4)(x+1)^3(1) + (x+1)^4(2x)$$

$$= 2x(x+1)^3[2x+(x+1)]$$

$$= 2x(x+1)^3(3x+1)$$

$$(b) y = (2x+1)(x+3)^3$$

$$\frac{dy}{dx} = (2x+1)(3)(x+3)^2 + (x+3)^3(2)$$

$$= (x+3)^2[6x+3+2(x+3)]$$

$$= (x+3)^2(8x+9)$$

$$(c) y = (x+2)^4(2x-3)^3$$

$$\frac{dy}{dx} = (x+2)^4(3)(2x-3)^2(2) +$$

$$(2x-3)^3(4)(x+2)^3$$

$$\frac{dy}{dx} = 6(x+2)^4(2x-3)^2 + 4(2x-3)^3(x+2)^3$$

$$\frac{dy}{dx} = 2(x+2)^3(2x-3)^2[3(x+2) + 2(2x-3)]$$

$$\frac{dy}{dx} = 2(x+2)^3(2x-3)^2[7x]$$

$$\frac{dy}{dx} = 14x(x+2)^3(2x-3)^2$$

$$8 \text{ (a) } f(x) = x(3-x)^4$$

$$f'(x) = x(4)(3-x)^3(-1) + (3-x)^4$$

$$f'(x) = -4x(3-x)^3 + (3-x)^4$$

$$f'(x) = (3-x)^3[-4x+3-x]$$

$$f'(x) = (3-x)^3(3-5x)$$

$$(b) f'(x) = 0$$

$$(3-x)^3[3-5x] = 0$$

$$x = 3 \text{ atau } \frac{3}{5}$$

$$9 \text{ (a) } y = \frac{3-x}{x^2+1}$$

$$\frac{dy}{dx} = \frac{(x^2+1)(-1) - (3-x)(2x)}{(x^2+1)^2}$$

$$\frac{dy}{dx} = \frac{(-x^2-1) - (6x+2x^2)}{(x^2+1)^2}$$

$$\frac{dy}{dx} = \frac{(-x^2-1) - 6x - 2x^2}{(x^2+1)^2}$$

$$\frac{dy}{dx} = \frac{-3x^2 - 6x - 1}{(x^2+1)^2}$$

$$9 \text{ (b) } y = \frac{(3x+1)^3}{2x+1}$$

$$\frac{dy}{dx} = \frac{(2x+1)(3)(3x+1)^2(3) - (3x+1)^3(2)}{(2x+1)^2}$$

$$\frac{dy}{dx} = \frac{9(2x+1)(3x+1)^2 - 2(3x+1)^3}{(2x+1)^2}$$

$$\frac{dy}{dx} = \frac{(3x+1)^2[18x+9 - 2(3x+1)]}{(2x+1)^2}$$

$$\frac{dy}{dx} = \frac{(3x+1)^2(12x+7)}{(2x+1)^2}$$

$$9 \text{ (c) } y = \frac{2x-1}{(x^2+3)^2}$$

$$\frac{dy}{dx} = \frac{(x^2+3)^2(2) - (2x-1)(2)(x^2+3)(2x)}{(x^2+3)^4}$$

$$\frac{dy}{dx} = \frac{2(x^2+3)[x^2+3 - 2x(2x-1)]}{(x^2+3)^4}$$

$$\frac{dy}{dx} = \frac{2[-3x^2+2x+3]}{(x^2+3)^3}$$

$$10 \text{ (a) } y = t^3 - 2t$$

$$\frac{dy}{dx} = 3t^2 - 2$$

$$x = t^2 + 3t$$

$$\frac{dx}{dt} = 2t + 3$$

$$\frac{dy}{dx} = \frac{\frac{dy}{dt}}{\frac{dx}{dt}} = \frac{3t^2 - 2}{2t + 3}$$

$$10 \text{ (b) } y = (t-1)^2 = t^2 - 2t + 1$$

$$\frac{dy}{dt} = 2t - 2$$

$$x = t^2 - 1$$

$$\frac{dx}{dt} = 2t$$

$$\frac{dy}{dx} = \frac{\frac{dy}{dt}}{\frac{dx}{dt}} = \frac{2t-2}{2t} = \frac{t-1}{t}$$

$$11 \text{ (a) } y = 3t^2$$

$$\frac{dy}{dt} = 6t$$

$$x = 2t + 1$$

$$\frac{dx}{dt} = 2$$

$$x = 2t + 1$$

$$t = \frac{x-1}{2}$$

$$\frac{dy}{dt} = \frac{\frac{dy}{dt}}{\frac{dx}{dt}} = \frac{6t}{2} = 3t = 3\left(\frac{x-1}{2}\right)$$

$$11 \text{ (b) } y = \frac{1}{4}u^8 = \frac{1}{4}(5x-2)^8 = 2(5x-2)^7(5)$$

$$= 10(5x-2)^7$$

Praktis Formatif 2.3

$$1 \text{ (a) } y = 2x^3 + 4x^2 - 6x - 3$$

$$\frac{dy}{dx} = 6x^2 + 8x - 6$$

$$\frac{d^2y}{dx^2} = 12x + 8$$

$$1 \text{ (b) } y = \frac{2x+5}{x} = 2 + \frac{5}{x}$$

$$\frac{dy}{dx} = -\frac{5}{x^2}$$

$$\frac{d^2y}{dx^2} = \frac{10}{x^3}$$

$$(c) y = \frac{3x}{x+3}$$

$$\frac{dy}{dx} = \frac{(x+3)(3) - 3x(1)}{(x+3)^2}$$

$$\frac{dy}{dx} = \frac{9}{(x+3)^2} = 9(x+3)^{-2}$$

$$\frac{d^2y}{dx^2} = -18(x+3)^{-3} = -\frac{18}{(x+3)^3}$$

$$(d) y = (2x+1)(3x^2-2) = 6x^3 - 4x + 3x^2 - 2$$

$$\frac{dy}{dx} = 18x^2 - 4 + 6x$$

$$\frac{d^2y}{dx^2} = 36x + 6$$

$$(e) y = (2x+1)^5$$

$$\frac{dy}{dx} = 5(2x+1)^4(2) = 10(2x+1)^4$$

$$\frac{d^2y}{dx^2} = 40(2x+1)^3(2) = 80(2x+1)^3$$

$$2 (a) f(x) = x^3 - 6x^2 + 9x + 2$$

$$f'(x) = 3x^2 - 12x + 9$$

$$f''(x) = 6x - 12$$

$$(b) f(x) = x^2 - \frac{2}{x}$$

$$f'(x) = 2x + \frac{2}{x^2}$$

$$f''(x) = 2 - \frac{4}{x^3}$$

$$(c) f(x) = \frac{1}{3x+4} = (3x+4)^{-1}$$

$$f'(x) = -(3x+4)^{-2}(3)$$

$$f''(x) = 6(3x+4)^{-3}(3) = \frac{18}{(3x+4)^3}$$

$$(d) f(x) = \frac{4x}{3x+1}$$

$$f'(x) = \frac{(3x+1)(4) - 4x(3)}{(3x+1)^2}$$

$$= \frac{4}{(3x+1)^2} = 4(3x+1)^{-2}$$

$$f''(x) = -8(3x+1)^{-3}(3) = -\frac{24}{(3x+1)^3}$$

$$(e) f(x) = \left(2x + \frac{1}{x}\right)^2 = 4x^2 + 4 + x^{-2}$$

$$f'(x) = 8x - 2x^{-3}$$

$$f''(x) = 8 + 6x^{-4} = 8 + \frac{6}{x^4}$$

Praktis Formatif 2.4a

$$1 (a) y = (x^2 + 3)^3$$

$$\frac{dy}{dx} = 3(x^2 + 3)^2(2x)$$

$$\frac{dy}{dx} = 6x(x^2 + 3)^2$$

$$m = 6(-1)[(-1)^2 + 3]^2 = -96$$

$$(b) y = \frac{x^2 + 3}{4x + 1}$$

$$\frac{dy}{dx} = \frac{(4x+1)(2x) - (x^2+3)(4)}{(4x+1)^2}$$

$$\frac{dy}{dx} = \frac{8x^2 + 2x - 4x^2 - 12}{(4x+1)^2}$$

$$\frac{dy}{dx} = \frac{4x^2 + 2x - 12}{(4x+1)^2}$$

$$m = \frac{-12}{1^2} = -12$$

$$(c) y = (9 - x^3)(1 + x^2) = 9 + 9x^2 - x^3 - x^5$$

$$\frac{dy}{dx} = 18x - 3x^2 - 5x^4$$

$$m = 18(2) - 3(2)^2 - 5(2)^4 = -56$$

$$(d) y = \frac{x+1}{x^2} = x^{-1} + x^{-2}$$

$$\frac{dy}{dx} = -x^{-2} - 2x^{-3}$$

$$\frac{dy}{dx} = -\frac{1}{x^2} - \frac{2}{x^3}$$

$$m = -\frac{1}{2^2} - \frac{2}{2^3} = -\frac{1}{4} - \frac{1}{4} = -\frac{1}{2}$$

$$(e) y = \frac{x-2}{x+1}$$

$$\frac{dy}{dx} = \frac{(x+1)-(x-2)}{(x+1)^2} = \frac{3}{(x+1)^2}$$

$$m = \frac{3}{(2+1)^2} = \frac{3}{9} = \frac{1}{3}$$

$$2 \quad y = hx^2 + kx$$

Lengkung melalui titik $\left(\frac{1}{4}, \frac{7}{8}\right)$.

$$\frac{7}{8} = h\left(\frac{1}{4}\right)^2 + k\left(\frac{1}{4}\right)$$

$$\frac{7}{8} = h\left(\frac{1}{16}\right) + k\left(\frac{1}{4}\right)$$

$$14 = h + 4k \quad \dots (1)$$

$$\frac{dy}{dx} = 2hx + k$$

$$4 = 2h\left(\frac{1}{4}\right) + k$$

$$8 = h + 2k \quad \dots (2)$$

$$(1) - (2): \quad \begin{array}{l} 2k = 6 \\ k = 3 \end{array}$$

Gantikan $k = 3$ ke dalam (2) :

$$8 = h + 2(3)$$

$$h = 2$$

$$3 \quad y = \frac{a}{x} + bx$$

Lengkung melalui titik (2, 7).

$$7 = \frac{a}{2} + 2b$$

$$14 = a + 4b \quad \dots (1)$$

$$\frac{dy}{dx} = \frac{-a}{x^2} + b$$

$$\frac{5}{2} = \frac{-a}{2^2} + b$$

$$10 = -a + 4b \quad \dots (2)$$

$$(1) + (2): \quad \begin{array}{l} 24 = 8b \\ b = 3 \end{array}$$

Gantikan $b = 3$ ke dalam (1) :

$$14 = a + 4(3)$$

$$a = 2$$

$$4 \quad y = fx + \frac{g}{x^2}$$

Lengkung melalui titik (2, 5).

$$5 = 2f + \frac{g}{2^2}$$

$$20 = 8f + g \quad \dots (1)$$

$$\frac{dy}{dx} = f - \frac{2g}{x^3}$$

$$1 = f - \frac{2g}{2^3}$$

$$1 = f - \frac{g}{4}$$

$$4 = 4f - g \quad \dots (2)$$

$$(1) + (2): \quad \begin{array}{l} 24 = 12f \\ f = 2 \end{array}$$

Gantikan $f = 2$ ke dalam (2) :

$$4 = 4(2) - g$$

$$g = 4$$

Praktis Formatif 2.4b

$$1 \text{ (a)} \quad y = 3x^2 - 2x - 5$$

$$m = \frac{dy}{dx} = 6x - 2$$

$$m = 6(2) - 2 = 10$$

Persamaan tangen ialah

$$y - 3 = 10(x - 2)$$

$$y = 10x - 20 + 3$$

$$y = 10x - 17$$

$$(b) \quad y = x + \frac{3}{x^2}$$

$$m = \frac{dy}{dx} = 1 - \frac{6}{x^3}$$

$$m = 1 - \frac{6}{1^3} = -5$$

Persamaan tangen ialah

$$y - 4 = -5(x - 1)$$

$$y = -5x + 5 + 4$$

$$y = -5x + 9$$

$$2 \text{ Apabila } x = 4, \quad y = x^3 - 8x^2 + 14x$$

$$y = 4^3 - 8(4)^2 + 14(4) = -8$$

$$y = x^3 - 8x^2 + 14x$$

$$m = \frac{dy}{dx} = 3x^2 - 16x + 14$$

$$m = 3(4)^2 - 16(4) + 14 = -2$$

Persamaan tangen ialah

$$y - (-8) = -2(x - 4)$$

$$y + 8 = -2x + 8$$

$$y = -2x$$

$$3 \quad y = \frac{3+x}{3-2x}$$

$$4 = \frac{3+x}{3-2x}$$

$$12 - 8x = 3 + x$$

$$9 = 9x$$

$$x = 1$$

$$m = \frac{dy}{dx} = \frac{(3-2x)(1) - (3+x)(-2)}{(3-2x)^2}$$

$$m = \frac{3-2x+2(3+x)}{(3-2x)^2}$$

$$m = \frac{3-2x+6+2x}{(3-2x)^2}$$

$$m = \frac{9}{(3-2x)^2}$$

Apabila $x = 1$, $m = \frac{9}{(3-2)^1} = 9$

(1, 4), $m = 9$

Persamaan tangen ialah

$$y - 4 = 9(x - 1)$$

$$y - 4 = 9x - 9$$

$$y = 9x - 5$$

$$4 \text{ (a) } y = \frac{1}{3}x^3 - \frac{1}{2}x^2 - 3x - 9$$

$$m = \frac{dy}{dx} = x^2 - x - 3$$

Apabila $x = 6$, $m = 6^2 - 6 - 3 = 27$

Kecerunan normal $-\frac{1}{27}$

Persamaan normal ialah

$$y - 27 = -\frac{1}{27}(x - 6)$$

$$27y - 729 = -x + 6$$

$$27y = -x + 735$$

$$\text{(b) } y = 2x + \frac{8}{x}$$

$$m = \frac{dy}{dx} = 2 - \frac{8}{x^2}$$

$$m = 2 - \frac{8}{(-1)^2} = -6$$

Kecerunan normal = $\frac{1}{6}$

Persamaan normal ialah

$$y - (-10) = \frac{1}{6}(x - (-1))$$

$$6y + 60 = x + 1$$

$$6y = x - 59$$

$$5 \quad y = \frac{x^2 + 2}{x} = x + \frac{2}{x}$$

$$\frac{dy}{dx} = 1 - \frac{2}{x^2} = \frac{1}{2}$$

$$\frac{2}{x^2} = \frac{1}{2}$$

$$x^2 = 4$$

$$x = \pm 2$$

$$y = \frac{(\pm 2)^2 + 2}{\pm 2}$$

$$y = \frac{4+2}{2} \text{ atau } y = \frac{4+2}{-2}$$

$$y = 3 \text{ atau } -3$$

Titik-titik yang dikehendaki ialah (2, 3) atau (-2, -3).

$$6 \quad y = 2x^2 - x + 5$$

$$m = \frac{dy}{dx} = 4x - 1$$

$$m = 4(1) - 1 = 3$$

Persamaan tangen ialah

$$y - 6 = 3(x - 1)$$

$$y = 3x + 3$$

Kecerunan garis serenjangan $-\frac{1}{3}$.

$$4x - 1 = -\frac{1}{3}$$

$$4x = \frac{2}{3}$$

$$x = \frac{1}{6}$$

7 Kecerunan garis $10y = x + 5$ ialah $\frac{1}{10}$.

Oleh itu, kecerunan tangen ialah -10 .

$$y = 3x^2 + hx + k$$

$$\frac{dy}{dx} = 6x + h$$

$$-10 = 6(-2) + h$$

$$h = 2$$

Lengkung melalui titik $(-2, 9)$.

$$y = 3x^2 + 2x + k$$

$$9 = 3(-2)^2 + 2(-2) + k$$

$$9 = 12 - 4 + k$$

$$k = 1$$

8 Kecerunan garis $y = 4x - 2$ ialah 4.

Kecerunan normal ialah $-\frac{1}{4}$.

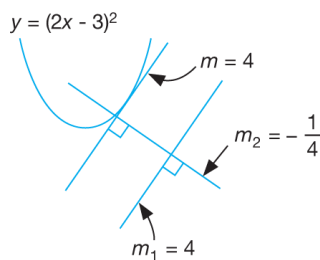

Oleh itu, kecerunan tangen ialah 4.

$$y = (2x - 3)^2$$

$$\frac{dy}{dx} = 2(2x - 3)(2) = 4$$

$$\begin{aligned} 8x - 12 &= 4 \\ x &= 2 \end{aligned}$$

Apabila $x = 2$, $y = (2 \times 2 - 3)^2 = 1$

Titik yang dikehendaki ialah $(1, 2)$.

Persamaan normal ialah

$$y - 1 = -\frac{1}{4}(x - 2)$$

$$4y - 4 = -x + 2$$

$$4y = -x + 6$$

9 (a) Persamaan tangen = $\frac{18 - 2}{7 + 1} = 2$

$$m = \frac{dy}{dx} = 2$$

$$2x - 4 = 2$$

$$x = 3$$

Apabila $x = 3$, $y = 3^2 - 4(3) - 3 = -6$

Koordinat titik R ialah $(3, -6)$.

(b) Kecerunan normal = $-\frac{1}{2}$

Persamaan normal ialah

$$y - (-6) = -\frac{1}{2}(x - 3)$$

$$2y + 12 = -x + 3$$

$$2y = -x - 9$$

Praktis Formatif 2.4c

1 (a) $y = 3x^2 - x^3$

$$\frac{dy}{dx} = 6x - 3x^2$$

$$\frac{d^2y}{dx^2} = 6 - 6x$$

Pada titik pusingan,

$$\frac{dy}{dx} = 0$$

$$6x - 3x^2 = 0$$

$$3x(2 - x) = 0$$

$$x = 0 \text{ atau } x = 2$$

Apabila $x = 0$,

$$y = 3(0)^2 - (0)^3 = 0$$

Oleh itu, $(0, 0)$ ialah titik pusingan.

$$\frac{d^2y}{dx^2} = 6 - 6(0) = 6 \text{ (positif)}$$

Maka, titik minimum ialah $(0, 0)$.

Apabila $x = 2$,

$$y = 3(2)^2 - (2)^3 = 4$$

Oleh itu, $(2, 4)$ ialah titik pusingan.

$$\frac{d^2y}{dx^2} = 6 - 6(2) = -6 \text{ (negatif)}$$

Maka, $(2, 4)$ ialah titik maksimum.

(b) $y = 4x + \frac{9}{x}$

$$\frac{dy}{dx} = 4 - \frac{9}{x^2}$$

$$\frac{d^2y}{dx^2} = \frac{18}{x^3}$$

Pada titik pusingan,

$$\frac{dy}{dx} = 0$$

$$4 - \frac{9}{x^2} = 0$$

$$\frac{9}{x^2} = 4$$

$$x^2 = \frac{9}{4}$$

$$x = \pm \frac{3}{2}$$

$$\frac{d^2y}{dx^2} = \frac{18}{x^3}$$

Apabila $x = \frac{3}{2}$,

$$y = 4\left(\frac{3}{2}\right) + \frac{9}{\left(\frac{3}{2}\right)} = 12$$

$\left(\frac{3}{2}, 12\right)$ ialah titik pusingan.

$$\frac{d^2y}{dx^2} = \frac{18}{\left(\frac{3}{2}\right)^3} = \frac{16}{3} \text{ (positif)}$$

Maka, $\left(\frac{3}{2}, 12\right)$ ialah titik minimum.

Apabila $x = -\frac{3}{2}$,

$$y = 4\left(-\frac{3}{2}\right) + \frac{9}{\left(-\frac{3}{2}\right)} = -12$$

$$\frac{d^2y}{dx^2} = \frac{18}{\left(-\frac{3}{2}\right)^3} = -\frac{16}{3} \text{ (negatif)}$$

$\left(-\frac{3}{2}, -12\right)$ ialah titik maksimum.

(c) $y = 4 - x^2 - \frac{16}{x^2}$

$$\frac{dy}{dx} = -2x + \frac{32}{x^3}$$

$$\frac{d^2y}{dx^2} = -2 - \frac{96}{x^4}$$

Pada titik pusingan,

$$\frac{dy}{dx} = 0$$

$$-2x + \frac{32}{x^3} = 0$$

$$\frac{32}{x^3} = 2x$$

$$x^4 = 16$$

$$x = \pm 2$$

Apabila $x = 2$,

$$y = 4 - 2^2 - \frac{16}{2^2}$$

$$y = -4$$

Maka, $(2, -4)$ ialah titik pusingan.

Pada titik pusingan,

$$\frac{dy}{dx} = 0$$

$$-2x + \frac{32}{x^3} = 0$$

$$\frac{32}{x^3} = 2x$$

$$x^4 = 16$$

$$x = \pm 2$$

Apabila $x = 2$,

$$y = 4 - 2^2 - \frac{16}{2^2} = -4$$

$(2, -4)$ ialah titik pusingan.

$$\frac{d^2y}{dx^2} = -2 - \frac{96}{2^4} = -8 \text{ (negatif)}$$

Maka, $(2, -4)$ ialah titik maksimum.

Apabila $x = -2$,

$$y = 4 - (-2)^2 - \frac{16}{(-2)^2} = -4$$

$(-2, -4)$ ialah titik pusingan.

$$\frac{d^2y}{dx^2} = -2 - \frac{96}{(-2)^4} = -8 \text{ (negatif)}$$

Maka, $(-2, -4)$ ialah titik maksimum.

(d) $y = x(x-3)^2$

$$y = x(x^2 - 6x + 9)$$

$$y = x^3 - 6x^2 + 9x$$

$$\frac{dy}{dx} = 3x^2 - 12x + 9$$

$$\frac{d^2y}{dx^2} = 6x - 12$$

Pada titik pusingan,

$$\frac{dy}{dx} = 0$$

$$3x^2 - 12x + 9 = 0$$

$$x^2 - 4x + 3 = 0$$

$$(x-3)(x-1) = 0$$

$$x = 3 \text{ atau } x = 1$$

Apabila $x = 3$,

$$y = 3(3-3)^2 = 0$$

Oleh itu, (3, 0) ialah titik pusingan.

$$\frac{d^2y}{dx^2} = 6(3) - 12 = 6 \text{ (positif)}$$

Maka, (3, 0) ialah titik minimum.

Apabila $x = 1$,

$$y = (1)(1-3)^2 = 4$$

Maka, (1, 4) ialah titik pusingan.

$$\frac{d^2y}{dx^2} = 6(1) - 12 = -6 \text{ (negatif)}$$

Maka, (1, 4) ialah titik maksimum.

$$(e) y = x^3 + 3x^2 - 9x - 1$$

$$\frac{dy}{dx} = 3x^2 + 6x - 9$$

$$\frac{d^2y}{dx^2} = 6x + 6$$

Pada titik pusingan,

$$\frac{dy}{dx} = 0$$

$$3x^2 + 6x - 9 = 0$$

$$x^2 + 2x - 3 = 0$$

$$(x+3)(x-1) = 0$$

$$x = -3 \text{ atau } x = 1$$

Apabila $x = -3$,

$$y = (-3)^3 + 3(-3)^2 - 9(-3) - 1 = 26$$

Oleh itu, (-3, 26) ialah titik pusingan.

$$\frac{d^2y}{dx^2} = 6(-3) + 6 = -12 \text{ (negatif)}$$

Maka, (-3, 26) ialah titik maksimum.

Apabila $x = 1$, $y = 1 + 3 - 9 - 1 = -6$

Oleh itu, (1, -6) ialah titik pusingan.

$$\frac{d^2y}{dx^2} = 6 + 6 = 12 \text{ (positif)}$$

Maka, (1, -6) ialah titik minimum.

$$2(a) y = hx^2 + \frac{k}{x^2}$$

Lengkung melalui titik (1, 17).

$$17 = h + k \dots (1)$$

$$\frac{dy}{dx} = 2hx - \frac{2k}{x^3}$$

$$-30 = 2h - 2k$$

$$-15 = h - k \dots (2)$$

$$(1) + (2) : 2h = 2$$

$$h = 1$$

Daripada (1) :

$$17 = 1 + k$$

$$k = 16$$

$$(b) y = x^2 + \frac{16}{x^2}$$

$$\frac{dy}{dx} = 2x - \frac{32}{x^3}$$

$$\frac{d^2y}{dx^2} = 2 + \frac{96}{x^4}$$

Pada titik pusingan,

$$\frac{dy}{dx} = 0$$

$$2x - \frac{32}{x^3} = 0$$

$$2x = \frac{32}{x^3}$$

$$x^4 = 16$$

$$x = \pm 2$$

Apabila $x = 2$,

$$y = 2^2 + \frac{16}{2^2} = 8$$

Oleh itu, (2, 8) ialah titik pusingan.

$$\frac{d^2y}{dx^2} = 2 + \frac{96}{2^4} = 8 \text{ (positif)}$$

Maka, (2, 8) ialah titik minimum.

Apabila $x = -2$,

$$y = (-2)^2 + \frac{16}{(-2)^2} = 8$$

Oleh itu, (-2, 8) ialah titik pusingan.

$$\frac{d^2y}{dx^2} = 2 + \frac{96}{(-2)^4} = 8 \text{ (positif)}$$

Maka, (-2, 8) ialah titik minimum.

Praktis Formatif 2.4d

1

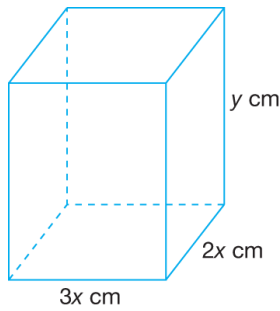

Katakan tinggi kuboid = y cm
 $4(3x) + 4(2x) + 4y = 200$
 $3x + 2x + y = 50$
 $y = 50 - 5x$

$V = (3x)(2x)(y)$
 $V = 6x^2y$
 $V = 6x^2(50 - 5x)$
 $V = 30x^2(10 - x)$ [Tertunjuk]
 $V = 300x^2 - 30x^3$

$\frac{dV}{dx} = 600x - 90x^2 = 0$
 $30x(20 - 3x) = 0$
 $x = \frac{20}{3}$

$V_{\text{maksimum}} = 300\left(\frac{20}{3}\right)^2 - 30\left(\frac{20}{3}\right)^3$
 $= \frac{40\,000}{9} \text{ cm}^3$

2

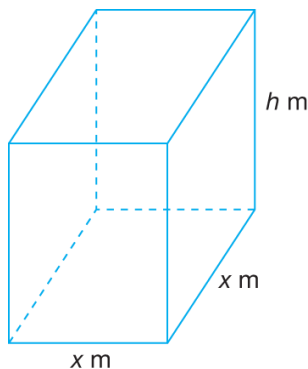

$V = x^2h = 8$

$h = \frac{8}{x^2}$

$A = 2x^2 + 4hx$

$A = 2x^2 + 4x\left(\frac{8}{x^2}\right)$

$A = 2x^2 + \frac{32}{x}$

$\frac{dA}{dx} = 4x - \frac{32}{x^2}$

Apabila $\frac{dA}{dx} = 4x - \frac{32}{x^2} = 0$,

$\frac{32}{x^2} = 4x$

$x^3 = 8$
 $x = 2$

$h = \frac{8}{x^2} = \frac{8}{2^2} = 2$

3

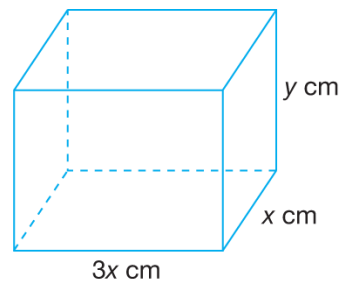

$A = 2(3x^2) + 2xy + 2(3xy) = 1274 \text{ cm}^2$

$6x^2 + 8xy = 1274$

$y = \frac{1274 - 6x^2}{8x}$

$P = 4(3x) + 4x + 4y$

$P = 16x + 4y$

$P = 16x + 4\left(\frac{1274 - 6x^2}{8x}\right)$

$P = 16x + \left(\frac{1274 - 6x^2}{2x}\right)$

$P = 16x + \left(\frac{637 - 3x^2}{x}\right)$

$P = 16x + \left(\frac{637}{x} - 3x\right)$

$$P = 13x + \frac{637}{x}$$

$$\frac{dP}{dx} = 13 - \frac{637}{x^2} = 0$$

$$\frac{637}{x^2} = 13$$

$$x^2 = 49$$

$$x = 7$$

$$P_{\text{minimum}} = 13(7) + \frac{637}{7} = 182 \text{ cm}$$

4 (a) Katakan $AB = DC = y$ cm

$$P = 2y + 2\pi r = 120$$

$$y + \pi r = 60$$

$$y = 60 - \pi r$$

$$L = 2ry - \pi r^2$$

$$L = 2r(60 - \pi r) - \pi r^2$$

$$L = 120r - 3\pi r^2 \text{ [Tertunjuk]}$$

$$(b) \frac{dL}{dr} = 120 - 6\pi r = 0$$

$$6\pi r = 120$$

$$r = \frac{120}{6\pi}$$

$$r = \frac{60}{\pi}$$

$$\frac{d^2L}{dr^2} = -6\pi < 0$$

Oleh itu, nilai L adalah maksimum.

5 (a) $V = 96 \text{ cm}^3$

$$\frac{1}{2}(4x)(3x)(y) = 96$$

$$6x^2y = 96$$

$$y = \frac{96}{6x^2}$$

$$y = \frac{16}{x^2}$$

$$A = (4x)(3x) + 3xy + 4xy + 5xy$$

$$A = 12x^2 + 12xy$$

$$A = 12x^2 + 12x\left(\frac{16}{x^2}\right)$$

$$A = 12x^2 + \frac{192}{x} \text{ [Tertunjuk]}$$

$$(b) \frac{dA}{dx} = 24x - \frac{192}{x^2} = 0$$

$$\frac{192}{x^2} = 24x$$

$$x^3 = 8$$

$$x = 2$$

$$h = 3x = 3(2) = 6 \text{ cm}$$

6 (a) $V = \pi r^2 h = 192\pi$

$$h = \frac{192}{r^2}$$

$$A = \pi r^2 + 2\pi r h + 2\pi r^2$$

$$A = 3\pi r^2 + 2\pi r\left(\frac{192}{r^2}\right)$$

$$A = 3\pi r^2 + 2\pi\left(\frac{192}{r}\right)$$

$$A = 3\pi r^2 + \pi\left(\frac{384}{r}\right) \text{ [Tertunjuk]}$$

$$(b) \frac{dA}{dr} = 6\pi r - \frac{384\pi}{r^2} = 0$$

$$6\pi r = \frac{384\pi}{r^2}$$

$$r^3 = 64$$

$$r = 4$$

$$A_{\text{maksimum}} = 3\pi(4)^2 + \pi\left(\frac{384}{4}\right)$$

$$= 48\pi + 96\pi$$

$$= 144\pi \text{ cm}^2$$

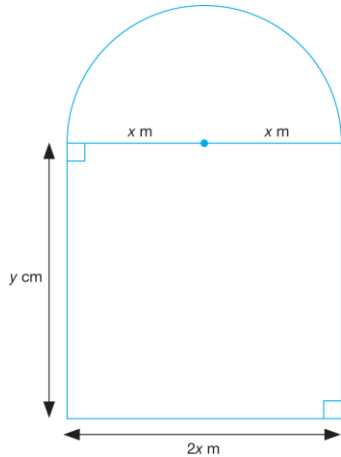

(a) Perimeter = 6 m
 $2y + 2x + \pi x = 6$
 $2y = 6 - 2x - \pi x$
 $y = \frac{6 - 2x - \pi x}{2}$
 A = Luas segi empat tepat + Luas semibulatan
 $= 2xy + \frac{1}{2}\pi x^2$
 $= 2x\left(\frac{6 - 2x - \pi x}{2}\right) + \frac{1}{2}\pi x^2$
 $= 6x - 2x^2 - \pi x^2 + \frac{1}{2}\pi x^2$
 $= 6x - 2x^2 - \frac{1}{2}\pi x^2$

(b) $\frac{dA}{dx} = 6 - 4x - \pi x$
 Apabila A mempunyai nilai pegun,
 $\frac{dA}{dx} = 0$
 $6 - 4x - \pi x = 0$
 $4x + \pi x = 6$
 $(4 + \pi)x = 6$
 $x = \frac{6}{4 + \pi}$

$$\frac{d^2A}{dx^2} = -4 - \pi \text{ (negatif)}$$

Maka, A adalah maksimum.

Maka, apabila luas permukaan tingkap itu adalah maksimum, lebar tingkap itu
 $= 2x$
 $= 2\left(\frac{6}{4 + 3.142}\right)$
 $= 1.680 \text{ m}$

Praktis Formatif 2.4e

1 $A = \pi r^2$

$$\frac{dA}{dr} = 2\pi r$$

$$\frac{dA}{dt} = \frac{dA}{dr} \times \frac{dr}{dt} = 2\pi(4) \times 0.5 = 4\pi \text{ cm}^2\text{s}^{-1}$$

2 (a) $V = \frac{4}{3}\pi r^3$

$$\frac{dV}{dr} = 4\pi r^2$$

$$\begin{aligned} \frac{dV}{dt} &= \frac{dV}{dr} \times \frac{dr}{dt} = 4\pi r^2 \times 0.5 \\ &= 4\pi(4)^2 \times 0.5 \\ &= 32\pi \text{ cm}^2\text{s}^{-1} \end{aligned}$$

(b) $A = 4\pi r^2$

$$\frac{dA}{dr} = 8\pi r$$

$$\frac{dA}{dt} = \frac{dA}{dr} \times \frac{dr}{dt} = 8\pi(4) \times 0.5 = 16\pi \text{ cm}^2\text{s}^{-1}$$

3 $V = \pi r^2 h = \pi(30)^2 h = 900\pi h$

$$\frac{dV}{dh} = 900\pi$$

$$\begin{aligned} \frac{dV}{dt} &= \frac{dV}{dh} \times \frac{dh}{dt} \\ &= \frac{1}{900\pi} \times 90 \\ &= \frac{1}{10\pi} \text{ cm}^2\text{s}^{-1} \end{aligned}$$

4 $V = 6\pi h^2 + \frac{1}{3}\pi h^3$

$$\frac{dV}{dh} = 12\pi h + \pi h^2$$

$$\begin{aligned} \frac{dh}{dt} &= \frac{dh}{dV} \times \frac{dV}{dt} \\ &= \frac{1}{12\pi h - \pi h^2} \times 3 \\ &= \frac{1}{12\pi(2) - \pi(2)^2} \times 3 \\ &= \frac{1}{20\pi} \times 3 \end{aligned}$$

$$= \frac{3}{20\pi} \text{ cms}^{-1}$$

5 Katakan luas $\Delta ABC = L \text{ cm}^2$

$$L = \frac{1}{2}(x)(3x) \sin 150^\circ$$

$$L = \frac{3}{2}x^2 \left(\frac{1}{2}\right)$$

$$L = \frac{3}{4}x^2$$

$$\frac{dL}{dx} = \frac{3}{2}x$$

$$\begin{aligned} \frac{dL}{dt} &= \frac{dL}{dx} \times \frac{dx}{dt} \\ &= \frac{3}{2}x \times (0.5) \\ &= \frac{3}{4}x \\ &= \frac{3}{4} \times 4 \\ &= 3 \text{ cm}^2\text{s}^{-1} \end{aligned}$$

6 $V = \frac{4}{3}\pi r^3$

$$\frac{dV}{dr} = 4\pi r^2$$

$$\begin{aligned} \frac{dr}{dt} &= \frac{dr}{dV} \times \frac{dV}{dt} \\ &= \frac{1}{4\pi r^2} \times 10\pi \\ &= \frac{1}{4\pi(4)^2} \times 10\pi \\ &= \frac{5}{32} \text{ cms}^{-1} \end{aligned}$$

7 (a) $V = x^3$

$$\frac{dV}{dx} = 3x^2$$

$$\frac{dV}{dt} = \frac{dV}{dx} \times \frac{dx}{dt} = 3(5)^2 \times (-2) = -150 \text{ cm}^3\text{s}^{-1}$$

(b) $A = 6x^2$

$$\frac{dA}{dx} = 12x$$

$$\frac{dA}{dt} = \frac{dA}{dx} \times \frac{dx}{dt} = 12(5) \times (-2) = -120 \text{ cm}^2\text{s}^{-1}$$

8 $\frac{h}{16} = \frac{r}{4}$

$$r = \frac{4}{16}h = \frac{h}{4}$$

$$V = \frac{1}{3}\pi r^2 h = \frac{1}{3}\pi \left(\frac{h}{4}\right)^2 h = \frac{1}{48}\pi h^3$$

$$\frac{dV}{dh} = \frac{1}{16}\pi h^2$$

$$\begin{aligned} \frac{dh}{dt} &= \frac{dh}{dV} \times \frac{dV}{dt} \\ &= \frac{16}{\pi(8)^2} \times 2 \\ &= \frac{1}{2\pi} \text{ cm s}^{-1} \end{aligned}$$

Praktis Formatif 2.4f

1 $y = 2x^3 - 8x^2 + 11$

$$\frac{dy}{dx} = 6x^2 - 16x$$

$$\begin{aligned} \delta y &= \frac{dy}{dx} \times \delta x \\ &= (6x^2 - 16x) \times 0.02 \\ &= (6(2)^2 - 16(2)) \times 0.02 \\ &= -0.16 \end{aligned}$$

y berkurang.

2 $y = 4x - \frac{6}{x}$

$$\frac{dy}{dx} = 4 + \frac{6}{x^2}$$

$$\delta y = \frac{dy}{dx} \times \delta x = \left(4 + \frac{6}{x^2}\right) \times (2 + k - 2)$$

$$\delta y = \left(4 + \frac{6}{2^2}\right) \times k = \frac{11}{2}k$$

3 $A = \pi r^2$

$$\frac{dA}{dr} = 2\pi r$$

$$\delta A = \frac{dA}{dr} \times \delta r = 2\pi(5) \times (0.03) = 0.3\pi \text{ cm}^2$$

4 $V = \frac{1}{3}\pi r^2 h$

$$V = \frac{1}{3}\pi r^2(5)$$

$$V = \frac{5}{3}\pi r^2$$

$$\frac{dV}{dr} = \frac{10}{3}\pi r$$

$$\delta V = \frac{dV}{dr} \times \delta r$$

$$= \frac{10}{3}\pi r \times (3.15 - 3)$$

$$= \frac{10}{3}\pi(3) \times (3.15 - 3)$$

$$= 1.5\pi \text{ cm}^3$$

5 $V = \pi r^2 h$

$$V = \pi(4)^2 h$$

$$V = 16\pi h$$

$$\delta V = \frac{dV}{dh} \times \delta h$$

$$= 16\pi \times 0.25$$

$$= 4\pi \text{ cm}^3$$

6 $V = \frac{4}{3}\pi r^3$

$$\frac{dV}{dr} = 4\pi r^2$$

$$\delta V = \frac{dV}{dr} \times \delta r$$

$$= 4\pi r^2 \times (-0.2)$$

$$= 4\pi(10)^2 \times (-0.2)$$

$$= 80\pi \text{ cm}^3$$

7 $A = 6x^2$

$$\frac{dA}{dx} = 12x$$

$$\delta A = \frac{dA}{dx} \times \delta x = 12x(-0.1) = -1.2(6)$$

$$= -7.2 \text{ cm}^2$$

8 $y = \frac{5}{x^3}$

$$\frac{dy}{dx} = -\frac{15}{x^4}$$

$$\text{Apabila } x = 4, \frac{dy}{dx} = -\frac{15}{4^4} = -\frac{15}{256}$$

(a) $y_{\text{baharu}} = y_{\text{asal}} + \frac{dy}{dx} \times \delta x$

$$\frac{5}{4.02^3} = \frac{5}{4^3} + \left(-\frac{15}{x^4}\right)(0.02)$$

$$= \frac{5}{64} + \left(-\frac{15}{4^4}\right)(0.02)$$

$$= 0.0770$$

(b) $y_{\text{baharu}} = y_{\text{asal}} + \frac{dy}{dx} \times \delta x$

$$\frac{5}{3.99^3} = \frac{5}{4^3} + \left(-\frac{15}{x^4}\right)(-0.01)$$

$$= \frac{5}{64} + \left(-\frac{15}{4^4}\right)(-0.01)$$

$$= 0.0787$$

Praktis Sumatif 2

1 $\text{had}_{x \rightarrow -4} \left(\frac{x^2 - 16}{x^4 + 4x} \right)$

$$= \text{had}_{x \rightarrow -4} \left[\frac{(x+4)(x-4)}{x(x+4)} \right]$$

$$= \text{had}_{x \rightarrow -4} \left[\frac{(x-4)}{x} \right]$$

$$= \frac{-4-4}{-4}$$

$$= 2$$

2 $y = x + \frac{1}{x} \dots (1)$

$$y + \delta y = x + \delta x + \frac{1}{x + \delta x} \dots (2)$$

(2) - (1) :

$$\delta y = \delta x + \frac{1}{x + \delta x} - \frac{1}{x}$$

$$\delta y = \delta x + \frac{x - (x + \delta x)}{x(x + \delta x)}$$

$$\delta y = \delta x + \frac{-\delta x}{x(x + \delta x)}$$

$$\frac{\delta y}{\delta x} = 1 + \frac{-1}{x(x + \delta x)}$$

$$\frac{dy}{dx} = \text{had}_{\delta x \rightarrow 0} \frac{\delta y}{\delta x}$$

$$\frac{dy}{dx} = \text{had}_{\delta x \rightarrow 0} \left[1 + \frac{-1}{x(x + \delta x)} \right]$$

$$\frac{dy}{dx} = 1 + \frac{-1}{x(x+0)}$$

$$\frac{dy}{dx} = 1 - \frac{1}{x^2}$$

$$3 \quad y = x^2(1-3x)^3$$

$$\begin{aligned} \frac{dy}{dx} &= x^2(3)(1-3x)^2(-3) + (1-3x)^3(2x) \\ &= x(1-3x)^2[-9x + 2(1-3x)] \\ &= x(1-3x)^2[-9x + 2 - 6x] \\ &= x(1-3x)^2(2-15x) \end{aligned}$$

$$4 \quad y = \frac{2}{t} \quad \left| \begin{array}{l} x = 2t - 1 \\ \frac{dx}{dt} = 2 \\ t = \frac{x+1}{2} \end{array} \right.$$

$$\frac{dy}{dx} = \frac{\frac{dy}{dt}}{\frac{dx}{dt}} = \frac{-\frac{2}{t^2}}{2} = -\frac{1}{t^2}$$

$$\frac{dy}{dx} = -\frac{1}{\left(\frac{x+1}{2}\right)^2} = -\frac{4}{(x+1)^2}$$

$$5 \quad y = (3-x)^2(2x-3)^4$$

$$\begin{aligned} \frac{dy}{dx} &= (3-x)^2(4)(2x-3)^3(2) + \\ &\quad (2x-3)^4(2)(3-x)(-1) \end{aligned}$$

$$\frac{dy}{dx} = 2(3-x)(2x-3)^3[4(3-x) - (2x-3)]$$

$$\frac{dy}{dx} = 2(3-x)(2x-3)^3(15-6x)$$

$$\frac{dy}{dx} = 2(3-x)(2x-3)^3(3)(5-2x)$$

$$\frac{dy}{dx} = 6(3-x)(2x-3)^3(5-2x)$$

$$6 \quad y = \frac{1}{3}u^6$$

$$y = \frac{1}{3}(3x-6)^6$$

$$\begin{aligned} \frac{dy}{dx} &= \frac{6}{3}(3x-6)^5(3) \\ &= 6(3x-6)^5 \end{aligned}$$

$$7 \quad \frac{dy}{dx} = \frac{\frac{dy}{dt}}{\frac{dx}{dt}} = \frac{14t^3}{2} = 7t^3$$

$$\text{Daripada } x = 2t + 3, \quad t = \frac{x-3}{2}$$

$$\begin{aligned} \text{Maka, } \frac{dy}{dx} &= 7\left(\frac{x-3}{2}\right)^3 \\ &= \frac{7}{8}(x-3)^3 \end{aligned}$$

$$8 \quad y = \frac{3x}{2x+5}$$

$$\begin{aligned} \frac{dy}{dx} &= \frac{(2x+5)(3) - (3x)(2)}{(2x+5)^2} \\ &= \frac{15}{(2x+5)^2} \end{aligned}$$

$$\frac{dy}{dx} = 15(2x+5)^{-2}$$

$$\begin{aligned} \frac{d^2y}{dx^2} &= -30(2x+5)^{-3}(2) \\ &= \frac{-60}{(2x+5)^3} \end{aligned}$$

$$9 \quad y = px^2 + \frac{q}{x}$$

Lengkung melalui titik (2, 3).

$$\begin{aligned} 3 &= p(2)^2 + \frac{q}{2} \\ 6 &= 8p + q \quad \dots (1) \end{aligned}$$

$$\begin{aligned} \frac{dy}{dx} &= 2px - \frac{q}{x^2} \\ \frac{3}{2} &= 2p(2) - \frac{q}{2^2} \\ 6 &= 16p - q \quad \dots (2) \end{aligned}$$

$$(1) + (2) : \\ 24p = 12$$

$$p = \frac{1}{2}$$

Daripada (1) :

$$6 = 8\left(\frac{1}{2}\right) + q$$

$$q = 2$$

10 Jika kecerunan normal ialah $-\frac{1}{9}$, maka

kecerunan tangen ialah 9.

$$y = (3x-2)^3$$

$$\frac{dy}{dx} = 3(3x-2)^2(3)$$

$$\frac{dy}{dx} = 9(3x-2)^2$$

$$9 = 9(3-2x)^2$$

$$(3x-2)^2 = 1$$

$$9x^2 - 12x + 4 = 1$$

$$9x^2 - 12x + 3 = 0$$

$$3x^2 - 4x + 1 = 0$$

$$(x-1)(3x-1) = 0$$

$$x = 1 \text{ atau } x = \frac{1}{3} \quad y = (3x-2)^3$$

$$\text{Apabila } x = 1, \quad y = (3-2)^3 = 1$$

$$\text{Apabila } x = \frac{1}{3}, \quad y = \left(3 \times \frac{1}{3} - 2\right)^3 = -1$$

Maka, titik-titik yang dikehendaki ialah

$$(1, 1) \text{ dan } \left(\frac{1}{3}, -1\right).$$

11 (a) Persamaan normal ialah

$$4y + x = p$$

$$4y = -x + p$$

$$y = -\frac{1}{4}x + \frac{p}{4}$$

$$\text{Kecerunan normal} = -\frac{1}{4}$$

$$\text{Kecerunan tangen} = 4$$

$$y = (2x-3)^2 - 4$$

$$\frac{dy}{dx} = 2(2x-3)(2)$$

$$\frac{dy}{dx} = 8x - 12$$

$$4 = 8x - 12$$

$$8x = 16$$

$$x = 2$$

$$\text{Apabila } x = 2,$$

$$y = (2 \times 2 - 3)^2 - 4 = -3$$

Maka, koordinat titik Q ialah

$$(2, -3).$$

$$4y + x = p$$

$$\text{At } (2, -3),$$

$$4(-3) + 2 = p$$

$$p = -10$$

(b) Persamaan tangen ialah

$$y - (-3) = 4(x - 2)$$

$$y + 3 = 4x - 8$$

$$y = 4x - 11$$

$$12 \quad y = \frac{2x-6}{x+3}$$

$$\frac{dy}{dx} = \frac{(x+3)(2) - (2x-6)(1)}{(x+3)^2}$$

$$\frac{dy}{dx} = \frac{2x+6-2x+6}{(x+3)^2}$$

$$\frac{dy}{dx} = \frac{12}{(x+3)^2}$$

Pada titik P (paksi- x), $y = 0$

$$y = \frac{2x-6}{x+3}$$

$$0 = \frac{2x-6}{x+3}$$

$$2x-6=0$$

$$x=3$$

$$\frac{dy}{dx} = \frac{12}{(3+3)^2}$$

$$m = \frac{12}{36} = \frac{1}{3}$$

$$13 \quad y = \frac{1}{x^2} - \frac{1}{x^3}$$

$$\frac{dy}{dx} = -\frac{2}{x^3} + \frac{3}{x^4}$$

$$\frac{d^2y}{dx^2} = \frac{6}{x^4} - \frac{12}{x^5}$$

$$x^4 \left(\frac{dy}{dx} + \frac{d^2y}{dx^2} \right) + x^2y + 5 = 0$$

$$x^4 \left(-\frac{2}{x^3} + \frac{3}{x^4} + \frac{6}{x^4} - \frac{12}{x^5} \right) + x^2 \left(\frac{1}{x^2} - \frac{1}{x^3} \right) + 5 = 0$$

$$-2x + 9 - \frac{12}{x} + 1 - \frac{1}{x} + 5 = 0$$

$$-2x + 15 - \frac{13}{x} = 0$$

$$-2x^2 + 15x - 13 = 0$$

$$2x^2 - 15x + 13 = 0$$

$$(2x-13)(x-1) = 0$$

$$x = \frac{13}{2} \text{ atau } x = 1$$

$$\begin{aligned}
 14 \quad y &= (x+1)^2(x-2) \\
 y &= (x^2 + 2x + 1)(x-2) \\
 y &= x^3 + 2x^2 + x - 2x^2 - 4x - 2 \\
 y &= x^3 - 3x - 2 \\
 \frac{dy}{dx} &= 3x^2 - 3 \\
 \frac{d^2y}{dx^2} &= 6x
 \end{aligned}$$

Pada titik pusingan,

$$\begin{aligned}
 \frac{dy}{dx} &= 0 \\
 3x^2 - 3 &= 0 \\
 x^2 - 1 &= 0 \\
 x^2 &= 1 \\
 x &= \pm 1
 \end{aligned}$$

Apabila $x = 1$, $y = 1^3 - 3(1) - 2 = -4$
 Oleh itu, $(1, -4)$ ialah titik pusingan.

$$\frac{d^2y}{dx^2} = 6(1) = 6 \text{ (positif)}$$

Maka, $(1, -4)$ ialah titik minimum.

Apabila $x = -1$, $y = (-1)^3 - 3(-1) - 2 = 0$

$$\frac{d^2y}{dx^2} = 6(-1) = -6 \text{ (negatif)}$$

Maka, $(-1, 0)$ ialah titik maksimum.

$$\begin{aligned}
 15 \text{ (a)} \quad y &= ax^3 + bx + c \\
 \frac{dy}{dx} &= 3ax^2 + b
 \end{aligned}$$

Pada titik pusingan,

$$\begin{aligned}
 \frac{dy}{dx} &= 0 \\
 3ax^2 + b &= 0 \\
 3a(1)^2 + b &= 0 \\
 3a + b &= 0 \dots (1)
 \end{aligned}$$

Lengkung melalui titik $(1, 1)$.

$$\begin{aligned}
 1 &= a(1)^3 + b(1) + c \\
 a + b + c &= 1 \dots (2)
 \end{aligned}$$

Lengkung melalui titik $(-1, 5)$.

$$\begin{aligned}
 5 &= a(-1)^3 + b(-1) + c \\
 -a - b + c &= 5 \dots (3)
 \end{aligned}$$

$$\begin{aligned}
 (2) - (3) : 2a + 2b &= -4 \\
 a + b &= -2 \dots (4)
 \end{aligned}$$

$$\begin{aligned}
 3a + b &= 0 \dots (1) \\
 (-) \frac{a + b}{2a} &= \frac{-2}{2} \dots (4) \\
 a &= 1
 \end{aligned}$$

Daripada (1) :

$$\begin{aligned}
 3(1) + b &= 0 \\
 b &= -3
 \end{aligned}$$

Daripada (2) :

$$\begin{aligned}
 1 - 3 + c &= 1 \\
 c &= 3
 \end{aligned}$$

$$(b) \quad y = x^3 - 3x + 3$$

$$\frac{dy}{dx} = 3x^2 - 3$$

$$\frac{d^2y}{dx^2} = 6x$$

Bagi $(1, 1)$:

$$\frac{d^2y}{dx^2} = 6(1) = 6 \text{ (positif)}$$

Maka, $(1, 1)$ ialah titik minimum.

For $(-1, 5)$:

$$\frac{d^2y}{dx^2} = 6(-1) = -6 \text{ (negatif)}$$

Maka, $(-1, 5)$ ialah titik maksimum.

$$16 \text{ (a)} \quad y = \frac{x^3}{3} - \frac{x^2}{2} - 2x + \frac{1}{6}$$

$$\begin{aligned}
 \frac{dy}{dx} &= \frac{3x^2}{3} - \frac{2x}{2} - 2 \\
 &= x^2 - x - 2
 \end{aligned}$$

Pada titik $A(1, -2)$,

$$m = \frac{dy}{dx} = 1^2 - 1 - 2 = -2$$

$$(b) \quad m \text{ (tangen)} = -2$$

$$m \text{ (normal)} = \frac{1}{2}$$

Persamaan normal pada titik $A(1, -2)$ is

$$y - (-2) = \frac{1}{2}(x - 1)$$

$$2y + 4 = x - 1$$

$$2y = x - 5$$

(c) Pada titik pusingan,

$$\frac{dy}{dx} = 0$$

$$x^2 - x - 2 = 0$$

$$(x-2)(x+1) = 0$$

$$x = 2 \text{ atau } -1$$

$x = -1$ tidak diterima kerana ia

kepunyaan $P\left(-1, 1\frac{1}{3}\right)$, iaitu titik

pusingan yang dinyatakan dalam soalan.

$$\therefore x = 2$$

Apabila $x = 2$,

$$y = \frac{2^3}{3} - \frac{2^2}{2} - 2(2) + \frac{1}{6} = -3\frac{1}{6}$$

Maka, Q ialah titik $\left(2, -3\frac{1}{6}\right)$.

$$\frac{d^2y}{dx^2} = 2x - 1$$

Apabila $x = 2$,

$$\frac{d^2y}{dx^2} = 2(2) - 1 = 3 \text{ (positif)}$$

Maka, $\left(2, -3\frac{1}{6}\right)$ ialah titik minimum.

$$17 \quad y = 12 - x^3 - \frac{48}{x} = 12 - x^3 - 48x^{-1}$$

$$\frac{dy}{dx} = -3x^2 + 48x^{-2} = -3x^2 + \frac{48}{x^2}$$

$$\frac{d^2y}{dx^2} = -6x - 96x^{-3} = -6x - \frac{96}{x^3}$$

Pada titik pusingan,

$$\frac{dy}{dx} = 0$$

$$-3x^2 + \frac{48}{x^2} = 0$$

$$\frac{48}{x^2} = 3x^2$$

$$x^4 = \frac{48}{3}$$

$$x^4 = 16$$

$$x = \pm 2$$

Apabila $x = 2$,

$$y = 12 - 2^3 - \frac{48}{2} = -20$$

$(2, -20)$ ialah titik pusingan.

$$\frac{d^2y}{dx^2} = -6(2) - \frac{96}{2^3} = -24 \text{ (negatif)}$$

Maka, $(2, -20)$ ialah titik maksimum.

Apabila $x = -2$,

$$y = 12 - (-2)^3 - \frac{48}{(-2)} = 44$$

$(-2, 44)$ ialah titik pusingan.

$$\frac{d^2y}{dx^2} = -6(-2) - \frac{96}{(-2)^3} = 24 \text{ (positif)}$$

Maka, $(-2, 44)$ ialah titik minimum.

18 (a) $A =$ Luas segi empat tepat $-$ Luas segi tiga

$$A = 60 \times 40 - \frac{1}{2}(3x)(40 - x)$$

$$A = 2400 - 60x + \frac{3}{2}x^2 \text{ [Tertunjuk]}$$

$$(b) \frac{dA}{dx} = -60 + 3x$$

Apabila A mempunyai nilai pegun,

$$\frac{dA}{dx} = 0$$

$$-60 + 3x = 0$$

$$x = 20$$

$$\frac{d^2A}{dx^2} = 3 \text{ (positif)}$$

Maka, nilai minimum A

$$= 2400 - 60(20) + \frac{3}{2}(20)^2$$

$$= 1800 \text{ cm}^2$$

$$19 (a) PR^2 = x^2 + 10^2$$

$$PR = \sqrt{x^2 + 100}$$

Jejari bulatan

$$= \frac{\sqrt{x^2 + 100}}{2}$$

$A =$ Luas bulatan $-$ Luas segi tiga

$$A = \pi \left(\frac{\sqrt{x^2 + 100}}{2} \right)^2 - \frac{1}{2}x(10)$$

$$A = \pi \left(\frac{x^2 + 100}{4} \right) - 5x$$

$$A = 25\pi + \frac{\pi}{4}x^2 - 5x \text{ [Tertunjuk]}$$

(b) Apabila A mempunyai nilai pegun,

$$\frac{dA}{dx} = 0$$

$$\frac{1}{2}\pi x - 5 = 0$$

$$\pi x = 10$$

$$x = \frac{10}{\pi}$$

$$\frac{d^2A}{dx^2} = \frac{1}{2}\pi \text{ (positif)}$$

Maka, nilai minimum A

$$= 25\pi + \frac{\pi}{4}\left(\frac{10}{\pi}\right)^2 - 5\left(\frac{10}{\pi}\right)$$

$$= 25\pi + \frac{25}{\pi} - \frac{50}{\pi}$$

$$= \left(25\pi - \frac{25}{\pi}\right) \text{cm}^2$$

20 (a) Perimeter segi empat tepat

$$2x + 2y = 72$$

$$x + y = 36$$

$$y = 36 - x$$

$$V = \pi r^2 h$$

$$V = \pi \left(\frac{x}{2}\right)^2 (y)$$

$$V = \pi \left(\frac{x^2}{4}\right)(36 - x)$$

$$V = \frac{\pi x^2}{4}(36 - x) \text{ [Tertunjuk]}$$

$$V = 9\pi x^2 - \frac{\pi}{4}x^3$$

$$\frac{dV}{dx} = 18\pi x - \frac{\pi}{4}(3x^2)$$

$$\frac{dV}{dx} = 18\pi x - \frac{3\pi}{4}x^2$$

Apabila V mempunyai nilai pegun

$$\frac{dV}{dx} = 0$$

$$18\pi x - \frac{3\pi}{4}x^2 = 0$$

$$18\pi x = \frac{3\pi}{4}x^2$$

$$6x = \frac{1}{4}x^2$$

$$24x = x^2$$

$$x^2 - 24x = 0$$

$$x(x - 24) = 0$$

$$x = 0 \text{ atau } x = 24$$

$x = 0$ tidak diterima.

$$\therefore x = 24$$

$$\frac{d^2V}{dx^2} = 18\pi - \frac{3\pi}{2}x$$

$$\begin{aligned} \text{Apabila } x = 24, \frac{d^2V}{dx^2} &= 18\pi - \frac{3\pi}{2}(24) \\ &= -18\pi \text{ (negatif)} \end{aligned}$$

Maka, nilai maksimum V

$$= 9\pi(24)^2 - \frac{\pi}{4}(24)^3$$

$$= 5\,184\pi - 3\,456\pi$$

$$= 1\,728\pi \text{ cm}^3$$

(b) $A = 2\pi r h$

$$A = 2\pi \left(\frac{x}{2}\right)(y)$$

$$A = \pi x(36 - x)$$

$$A = 36\pi x - \pi x^2$$

$$\frac{dA}{dx} = 36\pi - 2\pi x$$

Apabila A mempunyai nilai pegun,

$$\frac{dA}{dx} = 0$$

$$36\pi - 2\pi x = 0$$

$$18 - x = 0$$

$$x = 18$$

$$\frac{d^2A}{dx^2} = -2\pi \text{ (negatif)}$$

Maka, nilai maksimum A

$$= 36\pi(18) - \pi(18)^2$$

$$= 648\pi - 324\pi$$

$$= 324\pi \text{ cm}^2$$

21 $V = \pi r^2 h$

$$\pi r^2 h = 686\pi$$

$$r^2 h = 686$$

$$h = \frac{686}{r^2}$$

$$A = 2\pi r^2 + 2\pi r h$$

$$A = 2\pi r^2 + 2\pi r \left(\frac{686}{r^2}\right)$$

$$A = 2\pi r^2 + \frac{1\,372\pi}{r} \text{ [Tertunjuk]}$$

$$\frac{dA}{dr} = 4\pi r - \frac{1372\pi}{r^2}$$

Apabila A mempunyai nilai pegun,

$$\frac{dA}{dr} = 0$$

$$4\pi r - \frac{1372\pi}{r^2} = 0$$

$$4r = \frac{1372}{r^2}$$

$$r^3 = 343$$

$$r = 7$$

$$\frac{d^2A}{dr^2} = 4\pi + \frac{2744}{r^3} \text{ (positif)}$$

Maka, nilai minimum A

$$= 2\pi(7)^2 + \frac{1372\pi}{7}$$

$$= 294\pi \text{ cm}^2$$

22 (a) Perimeter = 100

$$2x + 2y = 100$$

$$x + y = 50$$

$$x = 50 - y$$

A = Luas segi empat tepat – Luas dua semibulatan

$$A = xy - \pi r^2$$

$$A = y(50 - y) - \pi \left(\frac{y}{2}\right)^2$$

$$A = 50y - y^2 - \frac{\pi y^2}{4}$$

$$A = 50y - \frac{4y^2 + \pi y^2}{4}$$

$$A = 50y - \left(\frac{4 + \pi}{4}\right) y^2 \text{ [Tertunjuk]}$$

$$(b) \frac{dA}{dy} = 50 - 2y\left(\frac{4 + \pi}{4}\right) = 50 - y\left(\frac{4 + \pi}{2}\right)$$

Apabila A mempunyai nilai pegun,

$$\frac{dA}{dy} = 0$$

$$50 - y\left(\frac{4 + \pi}{2}\right) = 0$$

$$y\left(\frac{4 + \pi}{2}\right) = 50$$

$$y = \frac{100}{4 + \pi}$$

$$\text{Lebar} = y = \frac{100}{4 + \pi} \text{ cm}$$

$$x = 50 - y$$

$$x = 50 - \left(\frac{100}{4 + \pi}\right)$$

$$x = \frac{50(4 + \pi) - 100}{4 + \pi}$$

$$x = \frac{200 + 50\pi - 100}{4 + \pi}$$

$$x = \frac{50\pi + 100}{4 + \pi}$$

$$\text{Panjang} = x = \frac{50\pi + 100}{4 + \pi} \text{ cm}$$

$$\frac{d^2A}{dy^2} = -\left(\frac{4 + \pi}{2}\right) \text{ [negatif]}$$

Maka, nilai A adalah maksimum.

23

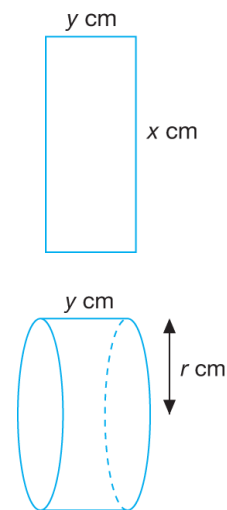

Perimeter segi empat tepat = 50 cm

$$2x + 2y = 50$$

$$x + y = 25$$

$$y = 25 - x$$

Perimeter bahagian kanan silinder adalah sama dengan panjang segi empat tepat

$$2\pi r = x$$

$$r = \frac{x}{2\pi}$$

Isi padu silinder

$$V = \pi r^2 h$$

$$V = \pi \left(\frac{x}{2\pi}\right)^2 y$$

$$V = \pi \left(\frac{x^2}{4\pi^2} \right) (25 - x)$$

$$V = \frac{1}{4\pi} (25x^2 - x^3)$$

$$\frac{dV}{dx} = \frac{1}{4\pi} (50x - 3x^2)$$

$$\frac{dV}{dx} = \frac{1}{4\pi} x(50 - 3x)$$

Apabila V mempunyai nilai pegun,

$$\frac{dV}{dx} = 0$$

$$\frac{1}{4\pi} x(50 - 3x) = 0$$

$$x = \frac{50}{3}$$

$$y = 25 - \frac{50}{3} = \frac{25}{3}$$

$$\frac{d^2V}{dx^2} = \frac{1}{4\pi} (50 - 6x)$$

Apabila $x = \frac{50}{3}$,

$$\frac{d^2V}{dx^2} = \frac{1}{4\pi} \left[50 - 6 \left(\frac{50}{3} \right) \right] = -\frac{25}{2\pi} (< 0)$$

Maka, isi padu silinder adalah maksimum.

Panjang = $16\frac{2}{3}$ cm

Lebar = $8\frac{1}{3}$ cm

24 $V = \text{Luas segi tiga } ABC \times CD$

$$V = \frac{1}{2} (x)(10) \times 5x$$

$$V = 5x(5x)$$

$$V = 25x^2$$

$$\frac{dV}{dx} = 50x$$

$$\frac{dV}{dt} = \frac{dV}{dx} \times \frac{dx}{dt}$$

$$= 50x \times 0.02$$

$$= 50(5) \times 0.02$$

$$= 5 \text{ cm}^3\text{s}^{-1}$$

25 $A = 2\pi r^2 + 2\pi r(12)$

$$A = 2\pi r^2 + 24\pi r$$

$$\frac{dA}{dr} = 4\pi r + 24\pi$$

$$\frac{dA}{dt} = \frac{dA}{dr} \times \frac{dr}{dt}$$

$$\frac{dA}{dt} = (4\pi r + 24\pi) \times 0.1$$

$$\frac{dA}{dt} = [4\pi(4) + 24\pi] \times 0.1$$

$$\frac{dA}{dt} = 4\pi \text{ cm}^2\text{s}^{-1}$$

26 $V = x^2 \left(\frac{1}{2}x \right)$

$$V = \frac{1}{2}x^3$$

$$\frac{dV}{dx} = \frac{3}{2}x^2$$

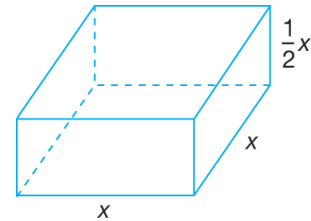

Apabila $A = 2x^2 \times 4 \left(\frac{1}{2}x \right) (x) = 4x^2$

Apabila $A = 1\,600$,

$$4x^2 = 1\,600$$

$$x^2 = 400$$

$$x = 20$$

$$\frac{dV}{dt} = \frac{dV}{dx} \times \frac{dx}{dt}$$

$$= \frac{3}{2}x^2 \times 0.02$$

$$= \frac{3}{2} (20)^2 \times 0.02$$

$$= 12 \text{ cm}^3\text{s}^{-1}$$

27

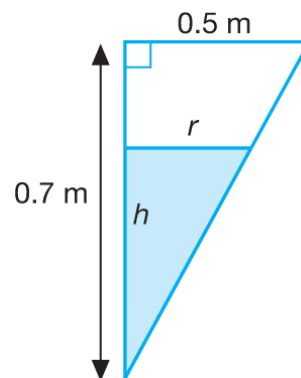

Dengan menggunakan nisbah segi tiga serupa,

$$\frac{r}{0.5} = \frac{h}{0.7}$$

$$r = \frac{h}{0.7} \times 0.5$$

$$r = \frac{5}{7}h$$

$$V = \frac{1}{3}\pi r^2 h$$

$$V = \frac{1}{3}\pi \left(\frac{5}{7}h\right)^2 h$$

$$V = \frac{1}{3}\pi \left(\frac{25}{49}h^2\right) h$$

$$V = \frac{25}{147}\pi h^3$$

$$\frac{dV}{dh} = \frac{25}{49}\pi h^2$$

$$\frac{dh}{dt} = \frac{dh}{dV} \times \frac{dV}{dt}$$

$$= \frac{49}{25\pi h^2} \times 0.1$$

$$= \frac{49}{25(3.142)(0.3)^2} \times 0.1$$

$$= 0.693 \text{ cms}^{-1}$$

28 (a) $m = 5x - 2$

$$\frac{dm}{dx} = 5$$

$$\frac{dx}{dt} = \frac{dx}{dm} \times \frac{dm}{dt}$$

$$= \frac{1}{5} \times 2$$

$$= \frac{2}{5} \text{ unit s}^{-1}$$

(b) $m = 5x - 2$ $y = -\frac{4}{m^2}$

$$\frac{dm}{dx} = 5$$

$$\frac{dy}{dm} = \frac{8}{m^3}$$

$$x = \frac{m+2}{5}$$

$$\frac{dy}{dx} = \frac{\frac{dy}{dm}}{\frac{dx}{dm}} = \frac{\frac{8}{m^3}}{\frac{1}{5}} = \frac{40}{m^3} = \frac{40}{(5x-2)^3}$$

(c) $\frac{\delta y}{\delta x} \approx \frac{dy}{dx}$

$$\delta y \approx \frac{dy}{dx} \times \delta x$$

$$= \frac{40}{(5x-2)^3} \times \left(\frac{4}{5}-1\right)$$

$$= \frac{40}{(5 \times 1 - 2)^3} \times \left(-\frac{1}{5}\right)$$

$$= -\frac{40}{27} \times \frac{1}{5}$$

$$= -\frac{8}{27}$$

29 (a)

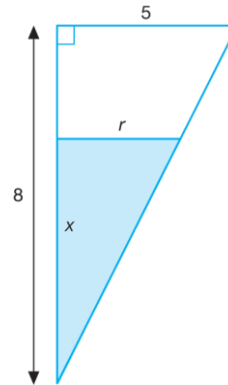

Dengan menggunakan nisbah segi tiga serupa,

$$\frac{r}{5} = \frac{x}{8}$$

$$r = \frac{5x}{8}$$

$$V = \frac{1}{3}\pi r^2 h$$

$$V = \frac{1}{3}\pi \left(\frac{5x}{8}\right)^2 (x)$$

$$V = \frac{25}{192}\pi x^3 \text{ [Tertunjuk]}$$

(b) $\frac{\delta V}{\delta x} \approx \frac{dV}{dx}$

$$\delta V \approx \frac{dV}{dx} \times \delta x$$

$$= \frac{25}{64}\pi x^2 \times (4.08 - 4)$$

$$= \frac{25}{64}\pi (4)^2 (0.08)$$

$$= 0.5\pi \text{ cm}^3$$

$$30 \quad y = \frac{27}{x^4}$$

$$\frac{dy}{dx} = \frac{-108}{x^5}$$

Apabila $x = 3$

$$\frac{dy}{dx} = \frac{-108}{3^5} = -\frac{4}{9}$$

$$(a) \quad y_{\text{baharu}} = y_{\text{asal}} + \frac{dy}{dx} \times \delta x$$

$$\begin{aligned} \frac{27}{2.99^4} &= \frac{27}{3^4} + \left(-\frac{4}{9}\right)(2.99-3) \\ &= 0.3378 \end{aligned}$$

$$\begin{aligned} (b) \quad \frac{27}{3.01^4} &= \frac{27}{3^4} + \left(-\frac{4}{9}\right)(3.01-3) \\ &= 0.3289 \end{aligned}$$